

# Altivar Machine ATV340

## Variable Speed Drives

### Installation Manual

NVE61069.06  
10/2025



# Legal Information

The information provided in this document contains general descriptions, technical characteristics and/or recommendations related to products/solutions.

This document is not intended as a substitute for a detailed study or operational and site-specific development or schematic plan. It is not to be used for determining suitability or reliability of the products/solutions for specific user applications. It is the duty of any such user to perform or have any professional expert of its choice (integrator, specifier or the like) perform the appropriate and comprehensive risk analysis, evaluation and testing of the products/solutions with respect to the relevant specific application or use thereof.

The Schneider Electric brand and any trademarks of Schneider Electric SE and its subsidiaries referred to in this document are the property of Schneider Electric SE or its subsidiaries. All other brands may be trademarks of their respective owner.

This document and its content are protected under applicable copyright laws and provided for informative use only. No part of this document may be reproduced or transmitted in any form or by any means (electronic, mechanical, photocopying, recording, or otherwise), for any purpose, without the prior written permission of Schneider Electric.

Schneider Electric does not grant any right or license for commercial use of the document or its content, except for a non-exclusive and personal license to consult it on an "as is" basis.

Schneider Electric reserves the right to make changes or updates with respect to or in the content of this document or the format thereof, at any time without notice.

**To the extent permitted by applicable law, no responsibility or liability is assumed by Schneider Electric and its subsidiaries for any errors or omissions in the informational content of this document, as well as any non-intended use or misuse of the content thereof.**

# Table of Contents

Safety Information.....	5
About the document .....	7
Introduction .....	16
Verifying the Absence of Voltage.....	17
Drive Overview.....	19
Accessories and Options.....	27
Display Terminals .....	29
Altivar Efficiency Calculator .....	32
Steps for Setting Up the Drive.....	33
Preliminary Instructions.....	34
Technical Data.....	36
Mechanical Data.....	37
Environmental Conditions.....	38
Dimensions and Weights .....	40
Electrical Data - Drive Ratings and Braking Resistors .....	48
Drive Ratings in Normal Duty .....	49
Drive Ratings in Heavy Duty .....	51
Braking Resistors.....	53
Electrical Data - Upstream Protective Device .....	54
Upstream Protective Device – Introduction.....	55
Prospective Short-Circuit Current.....	57
IEC Type Circuit-Breaker — with enclosure.....	60
IEC Fuses — with enclosure.....	62
UL Circuit-Breakers and Fuses .....	64
Drive Mounting .....	65
Mounting Conditions .....	66
Derating Curves .....	73
Mounting Procedures.....	80
Drive wiring .....	81
General Wiring Information.....	82
Wiring Instructions .....	83
Cable Length Instructions For Power Part.....	88
Cable Length Instructions For the Control Part .....	90
Electromagnetic Compatibility.....	92
General Wiring Diagrams .....	95
Wiring Diagrams for Frame Sizes 1...3: ATV340U07N4•... D22N4• .....	96
Wiring Diagrams for Frame Sizes 4 and 5: ATV340D30N4E... D75N4E .....	100
Built-in EMC Filter.....	104
Operation on an IT System .....	105
Disconnecting the Built-in EMC Filter.....	105
Power Part.....	110
Characteristics of the Power Part Terminals .....	111
Wiring the Power Part .....	117
Control Part.....	124

---

Arrangement and Characteristics of Control Block Terminals, Communication and I/O Ports .....	125
Control Terminals Electrical Data for Frame Sizes 1...3 .....	130
Control Terminals Electrical data for Frame Sizes 4 and 5 .....	142
Wiring The Control Part of Frame Sizes 4 and 5 .....	146
Product LEDs .....	153
SK EXT SRC Switch Configuration .....	157
SK-EXT-SRC Switch Configuration on Frame Sizes 1...3: ATV340U07N4•...D22N4• .....	158
SK-EXT-SRC Switch SW1 Configuration on Frame Sizes 4 and 5: ATV340D30N4E...D75N4E .....	159
PTO - DQ Switch (SW2) Configuration .....	161
PTO, Pulse Train Output Configuration on Frame Sizes 4 and 5.....	162
Digital Output Configuration on Frame Sizes 4 and 5 .....	164
Safe Torque Off STO Function .....	166
STO Safe Torque Off Wiring Diagram for Frame Sizes 1...3.....	167
STO Safe Torque Off Wiring Diagram for Frame Sizes 4 and 5 .....	167
Digital Inputs Wiring .....	168
Digital Inputs Wiring on Frame Sizes 1...3.....	169
Digital Inputs Wiring on Frame Sizes 4 and 5, Depending on Sink / Source Switch Configuration.....	171
Digital Outputs Wiring .....	174
Digital Outputs Wiring on Frame sizes 1...3.....	175
Digital Outputs Wiring on Frame sizes 4 and 5 .....	176
Relay Contacts Wiring .....	177
Output Relay with Inductive AC Loads .....	178
Output Relay with Inductive DC loads .....	179
Before Switching On.....	181
Maintenance .....	183
Scheduled Servicing .....	184
Long-term Storage.....	186
Decommissioning .....	187
Additional Support .....	188
Glossary .....	189

# Safety Information

## Important Information

Read these instructions carefully, and look at the equipment to become familiar with the device before trying to install, operate, service, or maintain it. The following special messages may appear throughout this documentation or on the equipment to warn of potential hazards or to call attention to information that clarifies or simplifies a procedure.



The addition of this symbol to a “Danger” or “Warning” safety label indicates that an electrical hazard exists which will result in personal injury if the instructions are not followed.



This is the safety alert symbol. It is used to alert you to potential personal injury hazards. Obey all safety messages that follow this symbol to avoid possible injury or death.

### **DANGER**

**DANGER** indicates a hazardous situation which, if not avoided, **will result in** death or serious injury.

### **WARNING**

**WARNING** indicates a hazardous situation which, if not avoided, **could result in** death or serious injury.

### **CAUTION**

**CAUTION** indicates a hazardous situation which, if not avoided, **could result in** minor or moderate injury.

### **NOTICE**

**NOTICE** is used to address practices not related to physical injury.

## Please Note

Electrical equipment should be installed, operated, serviced, and maintained only by qualified personnel. No responsibility is assumed by Schneider Electric for any consequences arising out of the use of this material.

A qualified person is one who has skills and knowledge related to the construction and operation of electrical equipment and its installation, and has received safety training to recognize and avoid the hazards involved.

## Qualification of Personnel

Only appropriately trained persons who are familiar with and understand the contents of this manual and all other pertinent product documentation are authorized to work on and with this product. In addition, these persons must have received safety training to recognize and avoid hazards involved. These persons must have sufficient technical training, knowledge and experience and be able to foresee and detect potential hazards that may be caused by using the product, by changing the settings and by the mechanical, electrical and electronic equipment of the entire system in which the product is used. All persons working on and with the product must be fully familiar with all applicable standards, directives, and accident prevention regulations when performing such work.

## Intended Use

This product is intended for industrial use according to this manual.

The product may only be used in compliance with all applicable safety standard and local regulations and directives, the specified requirements and the technical data. The product must be installed outside the hazardous ATEX zone. Prior to using the product, you must perform a risk assessment in view of the planned application. Based on the results, the appropriate safety measures must be implemented. Since the product is used as a component in an entire system, you must ensure the safety of persons by means of the design of this entire system (for example, machine design). Any use other than the use explicitly permitted is prohibited and can result in hazards.

# About the document

## Document Scope

The purpose of this document is:

- to give you mechanical and electrical information related to the Altivar ATV340 drive,
- to show you how to install and wire this drive.

## Validity Note

Original instructions and information given in the present document have been written in English (before optional translation).

This documentation is valid for the Altivar Machine ATV340•••E drives.

This documentation is valid for the Altivar Machine ATV340 drives.

The characteristics of the products described in this document are intended to match the characteristics that are available on [www.se.com](http://www.se.com). As part of our corporate strategy for constant improvement, we may revise the content over time to enhance clarity and accuracy. If you see a difference between the characteristics in this document and the characteristics on [www.se.com](http://www.se.com), consider [www.se.com](http://www.se.com) to contain the latest information.

## Product Related Information

Read and understand these instructions before performing any procedure with this device.

### DANGER

#### HAZARD OF ELECTRIC SHOCK, EXPLOSION OR ARC FLASH

- Only appropriately trained persons who are familiar with and fully understand the contents of the present manual and all other pertinent product documentation and who have received all necessary training to recognize and avoid hazards involved are authorized to work on and with this device system.
- Installation, adjustment, repair and maintenance must be performed by qualified personnel.
- Verify compliance with all local and national electrical code requirements as well as all other applicable regulations with respect to grounding of all equipment.
- Only use properly rated, electrically insulated tools and measuring equipment.
- Do not touch unshielded components or terminals with voltage present.
- Prior to performing any type of work on the device system, block the motor shaft to prevent rotation.
- Insulate both ends of unused conductors of the motor cable.
- Do not short across the DC bus terminals or the DC bus capacitors or the braking resistor terminals.

**Failure to follow these instructions will result in death or serious injury.**

### DANGER

#### HAZARD OF ELECTRIC SHOCK, EXPLOSION, OR ARC FLASH

Before performing work on the device system:

- Disconnect all power, including external control power that may be present. Take into account that the circuit breaker or main switch does not de-energize all circuits.
- Place a “Do Not Turn On” label on all power switches related to the device system.
- Lock all power switches in the open position.
- Wait 15 minutes to allow the DC bus capacitors to discharge.
- Verify the absence of voltage. (1)

Before applying voltage to the device system:

- Verify that the work has been completed and that the entire installation cannot cause hazards.
- If the mains input terminals and the motor output terminals have been grounded and short-circuited, remove the ground and the short circuits on the mains input terminals and the motor output terminals.
- Verify proper grounding of all equipment.
- Verify that all protective equipment such as covers, doors, grids is installed and/or closed.

**Failure to follow these instructions will result in death or serious injury.**

(1) Refer to Verifying the Absence of Voltage in the [ATV340 Installation manual](#).

Damaged products or accessories may cause electric shock or unanticipated equipment operation.

### DANGER

#### ELECTRIC SHOCK OR UNANTICIPATED EQUIPMENT OPERATION

Do not use damaged products or accessories.

**Failure to follow these instructions will result in death or serious injury.**

Contact your local Schneider Electric sales office if you detect any damage whatsoever.

This equipment has been designed to operate outside of any hazardous location. Only install this equipment in zones known to be free of a hazardous atmosphere.

**⚠ DANGER****POTENTIAL FOR EXPLOSION**

Install and use this equipment in non-hazardous locations only.

**Failure to follow these instructions will result in death or serious injury.**

Your application consists of a whole range of different interrelated mechanical, electrical, and electronic components, the device being just one part of the application. The device by itself is neither intended to nor capable of providing the entire functionality to meet all safety-related requirements that apply to your application. Depending on the application and the corresponding risk assessment to be conducted by you, a whole variety of additional equipment is required such as, but not limited to, external encoders, external brakes, external monitoring devices, guards, etc.

As a designer/manufacturer of machines, you must be familiar with and observe all standards that apply to your machine. You must conduct a risk assessment and determine the appropriate Performance Level (PL) and/or Safety Integrity Level (SIL) and design and build your machine in compliance with all applicable standards. In doing so, you must consider the interrelation of all components of the machine. In addition, you must provide instructions for use that enable the user of your machine to perform any type of work on and with the machine such as operation and maintenance in a safe manner.

The present document assumes that you are fully aware of all normative standards and requirements that apply to your application. Since the device cannot provide all safety-related functionality for your entire application, you must ensure that the required Performance Level and/or Safety Integrity Level is reached by installing all necessary additional equipment.

**⚠ WARNING****INSUFFICIENT PERFORMANCE LEVEL/SAFETY INTEGRITY LEVEL AND/OR UNINTENDED EQUIPMENT OPERATION**

- Conduct a risk assessment according to EN ISO 12100 and all other standards that apply to your application.
- Use redundant components and/or control paths for all critical control functions identified in your risk assessment.
- Implement all monitoring functions required to avoid any type of hazard identified in your risk assessment, for example, slipping or falling loads, in particular, if you do not operate the drive in closed loop mode which provides certain internal monitoring functions such as BRH3 [BRH b3], BRH4 [BRH b4] and BRH5 [BRH b5].
- Verify that the service life of all individual components used in your application is sufficient for the intended service life of your overall application.
- Perform extensive commissioning tests for all potential error situations to verify the effectiveness of the safety-related functions and monitoring functions implemented, for example, but not limited to, speed monitoring by means of encoders, short circuit monitoring for all connected equipment, correct operation of brakes and guards.
- Perform extensive commissioning tests for all potential error situations to verify that the load can be brought to a safe stop under all conditions.

**Failure to follow these instructions can result in death, serious injury, or equipment damage.**

A specific application note NHA80973 is available on hoisting machines and can be downloaded on [se.com](http://se.com). Product may perform unexpected movements because of incorrect wiring, incorrect settings, incorrect data or other errors.

**⚠ WARNING****UNANTICIPATED EQUIPMENT OPERATION**

- Carefully install the wiring in accordance with the EMC requirements.
- Do not operate the product with unknown or unsuitable settings or data.
- Perform a comprehensive commissioning test.

**Failure to follow these instructions can result in death, serious injury, or equipment damage.**

**▲ WARNING****LOSS OF CONTROL**

- The designer of any control scheme must consider the potential failure modes of control paths and, for critical control functions, provide a means to achieve a safe state during and after a path failure. Examples of critical control functions are emergency stop, overtravel stop, power outage and restart.
- Separate or redundant control paths must be provided for critical control functions.
- System control paths may include communication links. Consideration must be given to the implications of unanticipated transmission delays or failures of the link.
- Observe all accident prevention regulations and local safety guidelines (1).
- Each implementation of the product must be individually and thoroughly tested for proper operation before being placed into service.

**Failure to follow these instructions can result in death, serious injury, or equipment damage.**

(1) For USA: Additional information, refer to NEMA ICS 1.1 (latest edition), Safety Guidelines for the Application, Installation, and Maintenance of Solid State Control and to NEMA ICS 7.1 (latest edition), Safety Standards for Construction and Guide for Selection, Installation and Operation of Adjustable-Speed Drive Systems.

The temperature of the products described in this manual may exceed 80 °C (176 °F) during operation.

**▲ WARNING****HOT SURFACES**

- Ensure that any contact with hot surfaces is avoided.
- Do not allow flammable or heat-sensitive parts in the immediate vicinity of hot surfaces.
- Verify that the product has sufficiently cooled down before handling it.
- Verify that the heat dissipation is sufficient by performing a test run under maximum load conditions.

**Failure to follow these instructions can result in death, serious injury, or equipment damage.**

**NOTICE****DESTRUCTION DUE TO INCORRECT MAINS VOLTAGE**

Before switching on and configuring the product, verify that it is approved for the mains voltage.

**Failure to follow these instructions can result in equipment damage.**

## General Cybersecurity Information

In recent years, the growing number of networked machines and production plants has seen a corresponding increase in the potential for cyber threats, such as unauthorized access, data breaches, and operational disruptions. You must, therefore, consider all possible cybersecurity measures to help protect assets and systems against such threats.

To help keep your Schneider Electric products secure and protected, it is in your best interest to implement the cybersecurity best practices as described in the [Cybersecurity Best Practices](#) document.

Schneider Electric provides additional information and assistance:

- [Subscribe to the Schneider Electric security newsletter.](#)
- [Visit the Cybersecurity Support Portal web page to:](#)
  - [Find Security Notifications.](#)
  - [Report vulnerabilities and incidents.](#)
- [Visit the Schneider Electric Cybersecurity and Data Protection Posture web page to:](#)
  - [Access the cybersecurity posture.](#)
  - [Learn more about cybersecurity in the cybersecurity academy.](#)
  - [Explore the cybersecurity services from Schneider Electric.](#)

## Environmental Data

The Environmental Data Program is a framework for how we measure, categorize, and compare the environmental attributes and footprint of our products.

Using a rigorous, fact-based methodology, the program provides environmental data from across the product lifecycle.

Five data categories across the product lifecycle

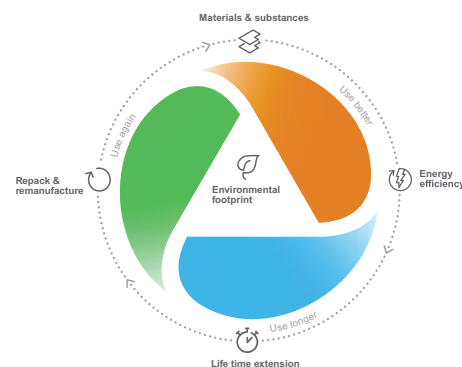

**Use Better:** How sustainable a product is, including environmental footprint, materials and substances, packaging, and energy efficiency.

**Use Longer:** How a product's life time can be effectively extended in terms of reparability and updatability.

**Use Again:** How a product can be reused, from dismantling and remanufacturing to recyclability and manufacturer take back.

With this transparent, verified data, customers and partners are empowered to make conscious environmental choices and accurately evaluate and report on sustainability performance.

All our hardware offers have an associated environmental data available on [se.com](#) product pages.

Refer to [Environmental Data Program](#) for more information.

## Related Documents

Use your tablet or your PC to quickly access detailed and comprehensive information on all our products on [www.se.com](http://www.se.com).

To find documents online, visit the Schneider Electric download center ([www.se.com/ww/en/download/](http://www.se.com/ww/en/download/)).

The internet site provides the information you need for products and solutions:

- The whole catalog for detailed characteristics and selection guides,
- The CAD files to help design your installation, available in over 20 different file formats,
- All software and firmware to maintain your installation up to date,
- A large quantity of White Papers, Environment documents, Application solutions, Specifications... to gain a better understanding of our electrical systems and equipment or automation,
- And finally all the User Guides related to your drive, listed below:

Title of Documentation	Reference number
ATV340 Catalog	DIA2ED2160701EN (English) DIA2ED2160701FR (French)
ATV340 Getting Started - Video	FA367923 FAQ (English) 
ATV340 Getting Started	NVE37643 (English) NVE37642 (French) NVE37644 (German) NVE37646 (Spanish) NVE37647 (Italian) NVE37648 (Chinese) NVE37643PT (Portuguese)
ATV340 Getting Started Annex (SCCR)	NVE37641 (English)
Wiring Diagrams for Frame Sizes S1, S2, S3	NVE97896 (English)
ATV340 Installation Manual	NVE61069 (English) NVE61071 (French) NVE61074 (German) NVE61075 (Spanish) NVE61078 (Italian) NVE61079 (Chinese) NVE61069PT (Portuguese) NVE61069TR (Turkish)
ATV340 Programming Manual	NVE61643 (English) NVE61644 (French) NVE61645 (German) NVE61647 (Spanish) NVE61648 (Italian)

Title of Documentation	Reference number
	NVE61649 (Chinese) NVE61643PT (Portuguese) NVE61643TR (Turkish)
ATV340 Modbus manual (Embedded)	NVE61654 (English)
ATV340 Ethernet manual (Embedded)	NVE61653 (English)
ATV340 PROFIBUS DP manual (VW3A3607)	NVE61656 (English)
ATV340 DeviceNet manual (VW3A3609)	NVE61683 (English)
Altivar dPAC Module user guide (VW3A3530D)	NNZ13577 (English)
ATV340 PROFIsafe manual (VW3A3807)	BRU32661 (English)
ATV340 PROFINET manual (VW3A3627)	NVE61678 (English)
ATV340 PROFINET manual (VW3A3647)	BQT46621 (English)
ATV340 CANopen manual (VW3A3608, 618, 628)	NVE61655 (English)
ATV340 POWERLINK manual - (VW3A3619)	NVE61681 (English)
ATV340 EtherCAT manual - (VW3A3601)	NVE61686 (English)
ATV340 Sercos III manual (embedded)	PHA33735 (English) PHA33737 (French) PHA33738 (German) PHA33739 (Spanish) PHA33740 (Italian) PHA33741 (Chinese)
ATV340 Communication Parameters	NVE61728 (English)
ATV340 Embedded Safety Function Manual	NVE64143 (English)
ATV340 DC Bus Sharing Technical Note PHA25027	PHA25027 (English)
ATV340 Safety functions Manual with Module VW3A3802	NVE61741 (English) NVE61742 (French) NVE61745 (German) NVE61747 (Spanish) NVE61749 (Italian) NVE61752 (Chinese) NVE61741PT (Portuguese) NVE61741TR (Turkish)
ATV340 CIP Safety functions manual with Module VW3A3809	JYT89148 (English)
SoMove FDT	SoMove_FDT (English, French, German, Spanish, Italian, Chinese)
Altivar 340: DTM	ATV340_DTM_Library_EN (English) ATV340_DTM_Lang_FR (French) ATV340_DTM_Lang_DE (German) ATV340_DTM_Lang_SP (Spanish) ATV340_DTM_Lang_IT (Italian) ATV340_DTM_Lang_CN (Chinese)
Altivar Application Note for Hoisting	NHA80973 (English)
Recommended Cybersecurity Best Practices	CS-Best-Practices-2019-340 (English)

## Information on Non-Inclusive or Insensitive Terminology

As a responsible, inclusive company, Schneider Electric is constantly updating its communications and products that contain non-inclusive or insensitive terminology. However, despite these efforts, our content may still contain terms that are deemed inappropriate by some customers.

## Electronic product data sheet

Scan the QR code in front of the drive to get the product data sheet.

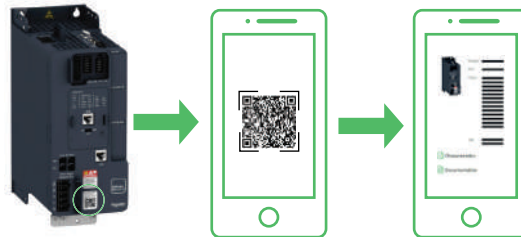

## Terminology used in this document

The technical terms, terminology, and the corresponding descriptions in this manual normally use the terms or definitions in the relevant standards.

Among others, these standards include:

- ISO 13849: The Foundation of Functional Safety in the Machinery
- IEC 60204-1: Safety of machinery - Electrical equipment of machines – Part 1: General requirements.
- IEC 61010: Safety requirements for electrical equipment for measurement, control, and laboratory use.
- IEC 61158 series: Industrial communication networks - Fieldbus specifications
- IEC 61508 Ed.2 series: Functional safety of electrical/electronic/programmable electronic safety-related.
- IEC 61784 series: Industrial communication networks - Profiles.
- IEC 61784-5-3: Industrial communication networks - Profiles - Part 5-3: Installation of fieldbuses - Installation profiles for CPF 3
- IEC 61800 series: Adjustable speed electrical power drive systems.
- IEC 61918: Industrial communication networks - Installation of communication networks in industrial premises.
- IEC 62443: Security for industrial automation and control systems.

In the area of drive systems this includes, but is not limited to, terms such as **error**, **error message**, **failure**, **fault**, **fault reset**, **protection**, **safe state**, **safety function**, **warning**, **warning message**, and so on.

In addition, the term **zone of operation** is used in conjunction with the description of specific hazards, and is defined as it is for a **hazard zone** or **danger zone** in the EC Machinery Directive (2006/42/EC) and in ISO 12100-1.

## Contact us

Select your country on [www.se.com/contact](http://www.se.com/contact).

Schneider Electric Industries SAS

Head Office

35, rue Joseph Monier

92500 Rueil-Malmaison

France

# Introduction

## What's in This Part

Verifying the Absence of Voltage .....	17
Drive Overview .....	19
Accessories and Options .....	27
Display Terminals .....	29
Altivar Efficiency Calculator .....	32
Steps for Setting Up the Drive .....	33
Preliminary Instructions .....	34

# Verifying the Absence of Voltage

## Instructions

The DC bus voltage level is determined by measuring the voltage between the DC bus terminals PA/+ and PC/-.

The location of the DC bus terminals depends on the drive model.

Identify your drive model by referring to the nameplate of the drive.

Then, refer to the chapter for the location of the DC bus terminals PA/+ and PC/-.

Then, refer to the chapter *Wiring the Power Part*, page 117 for the location of the DC bus terminals PA/+ and PC/-.

**Read and understand these instructions before performing any procedure with this device.**

### **DANGER**

#### **HAZARD OF ELECTRIC SHOCK, EXPLOSION OR ARC FLASH**

- Only appropriately trained persons who are familiar with and fully understand the contents of the present manual and all other pertinent product documentation and who have received all necessary training to recognize and avoid hazards involved are authorized to work on and with this device system.
- Installation, adjustment, repair and maintenance must be performed by qualified personnel.
- Verify compliance with all local and national electrical code requirements as well as all other applicable regulations with respect to grounding of all equipment.
- Only use properly rated, electrically insulated tools and measuring equipment.
- Do not touch unshielded components or terminals with voltage present.
- Prior to performing any type of work on the device system, block the motor shaft to prevent rotation.
- Insulate both ends of unused conductors of the motor cable.
- Do not short across the DC bus terminals or the DC bus capacitors or the braking resistor terminals.

**Failure to follow these instructions will result in death or serious injury.**

**⚡⚠ DANGER****HAZARD OF ELECTRIC SHOCK, EXPLOSION, OR ARC FLASH**

Before performing work on the device system:

- Disconnect all power, including external control power that may be present. Take into account that the circuit breaker or main switch does not de-energize all circuits.
- Place a “Do Not Turn On” label on all power switches related to the device system.
- Lock all power switches in the open position.
- Wait 15 minutes to allow the DC bus capacitors to discharge.
- Verify the absence of voltage. (1)

Before applying voltage to the device system:

- Verify that the work has been completed and that the entire installation cannot cause hazards.
- If the mains input terminals and the motor output terminals have been grounded and short-circuited, remove the ground and the short circuits on the mains input terminals and the motor output terminals.
- Verify proper grounding of all equipment.
- Verify that all protective equipment such as covers, doors, grids is installed and/or closed.

**Failure to follow these instructions will result in death or serious injury.**

(1) Refer to the procedure in the present document, page 18.

## Procedure

Perform the following actions to verify the absence of voltage

Step	Action
1	Measure the voltage on the DC bus between the DC bus terminals (PA/+ and PC/-) using a properly rated voltmeter to verify that the voltage is less than 42 Vdc
2	If the DC bus capacitors do not discharge properly, contact your local Schneider Electric representative.  Do not repair or operate the product.
3	Verify that no other voltage is present in the drive system.

# Drive Overview

## The Range

ATV340 is available in 5 frame sizes.

The drives are designed to operate with a supply voltage range of 380...480 Vac with a tolerance of -15...10 %.

## Frame Sizes 1, 2 and 3

Frame Size 1, 2 and 3 are available in 3 versions.

ATV340...**N4**: These drives include...



- 3 general-purpose slots (marked GP-\*\*) for optional...
  - GP-SF: I/O or Safety module
  - GP-ENC: I/O or Encoder module
  - GP-FB: I/O or Fieldbus module

ATV340...**N4E**: These drives include...

- 2 Advanced Ethernet RJ45 ports
  - NOTE:** please refer to the ATV340 Ethernet manual (Embedded) NVE61653
- 2 general-purpose slots (marked GP-\*\*) for optional...
  - GP-SF: I/O or Safety module
  - GP-ENC: I/O or Encoder module

ATV340...**N4S**: These drives include...

- 2 Sercos III RJ45 ports
  - NOTE:** Please refer to the ATV340 Sercos III manual (Embedded).
- 2 general-purpose slots (marked GP-\*\*) for optional...
  - GP-SF: I/O
  - GP-ENC: I/O or Encoder module

Frame size 1	Frame size 2
3-phase 380...480 V, 0.75 kW...4 kW, 1...5 HP	3-phase 380...480 V, 5.5 kW...7.5 kW, 7...10 HP
	
ATV340U07N4•... ATV340U40N4•	ATV340U55N4•... ATV340U75N4•
Frame size 3	
3-phase 380...480 V, 11 kW...22 kW, 15...30 HP	
	
ATV340D11N4•... ATV340D22N4•	

## Frame Sizes 4 and 5

These drives include:

- 2 slots for optional module:
  - Slot A: for general-purpose I/O or Fieldbus option
  - Slot B: for general-purpose I/O or Encoder option
  - Slot C: for accessory general-purpose I/O or Safety option using the option module adapter accessory
- A third slot C, made possible by the additional module support option VW3A3800.

This option allows the following modules to be added:

- Safety module VW3A3802,
- Extended I/O module VW3A3203,
- Extended relay module VW3A3204,

**NOTE:** Contact your local Schneider Electric representative for firmware version compatibility between the module and the drive.



- 2 Advanced Ethernet RJ45 ports

### 2 frame sizes IP20

Frame size 4	Frame size 5
3-phase 380...480 V, 30 kW...37 kW, 40...50 HP	3-phase 380...480 V, 45 kW...75 kW, 60...100 HP
	
ATV340D30N4E... ATV340D37N4E	ATV340D45N4E... ATV340D75N4E

## Products intended to Cabinet Integration

2 frame sizes IP20 on upper part and IP00 on lower part

Frame size 4	Frame size 5
3-phase 380...480 V, 30...37 kW, 40...50 HP	3-phase 380...480 V, 45...75 kW, 75...100 HP
 <p>A vertical, dark grey variable speed drive with a green top section. The Schneider logo is visible at the bottom.</p>	 <p>A vertical, dark grey variable speed drive with a green top section, larger than the frame size 4 model. The Schneider logo is visible at the bottom.</p>
ATV340D30N4EZ... ATV340D37N4EZ•	ATV340D45N4EZ... ATV340D75N4EZ•

# Catalog Number Description

	<b>ATV</b>	<b>340</b>	<b>U</b>	<b>22</b>	<b>N4</b>	<b>E</b>
<b>Product Range</b>	ATV Altivar					
<b>Product Type</b>	340 High performance drive for machines					
<b>Factor for power rating</b>	U power x 0.1 D power x 1					
<b>Power rating [W]</b>	07 - 11 - 15 - 18 - 22 - 30 - 37 - 40 - 45 - 55 - 75					
<b>Power part supply</b>	N4 3-phase, 400 Vac (380...480 Vac)					
<b>Product Design</b>	I/O product version, frame sizes 1...3 only E Ethernet product version, frame sizes 1...3 only S Sercos III product version, frame sizes 1...3 only Z For cabinet integration, without top cover, conduit box and display terminal					

**NOTE:** see the catalog for possible combinations.

## Communication

The ATV340 drives offer a wide choice of communication protocols, whether integrated or available with an optional communication card.

### Frame Size 1 to 3

Drive Type	Communication		
	Integrated	Optional	
ATV340•••N4	2 ports Modbus serial line	Profibus DP V1 ProfiNet DeviceNet CANopen DC CANopen Sub-D CANopen open type EtherCat	POWERLINK Additional digital & analog I/O Additional output relays Digital encoder interface module 5/12V Analog encoder interface module Resolver encoder interface module Safety module advanced
ATV340•••N4E	Dual port for Ethernet IP/Modbus TCP, 2 ports Modbus serial line	Additional digital & analog I/O Additional output relays	Analog encoder interface module Resolver encoder interface module
ATV340•••N4S	Dual port for SERCOS III, 2 ports for Modbus serial line	Digital encoder interface module 5/12v	Safety module advanced

**Frame Size 4 and 5**

Drive Type	Communication		
	Integrated	Optional	
ATV340•••N4E•	Dual port for Ethernet IP/Modbus TCP, 2 ports Modbus serial line	Profibus DP V1 ProfiNet DeviceNet CANopen DC CANopen Sub-D CANopen open type EtherCat	Additional digital & analog I/O Additional output relays Digital encoder interface module 5/12V Analog encoder interface module Resolver encoder interface module Safety module advanced

# Nameplate example

The nameplate contains the following data:

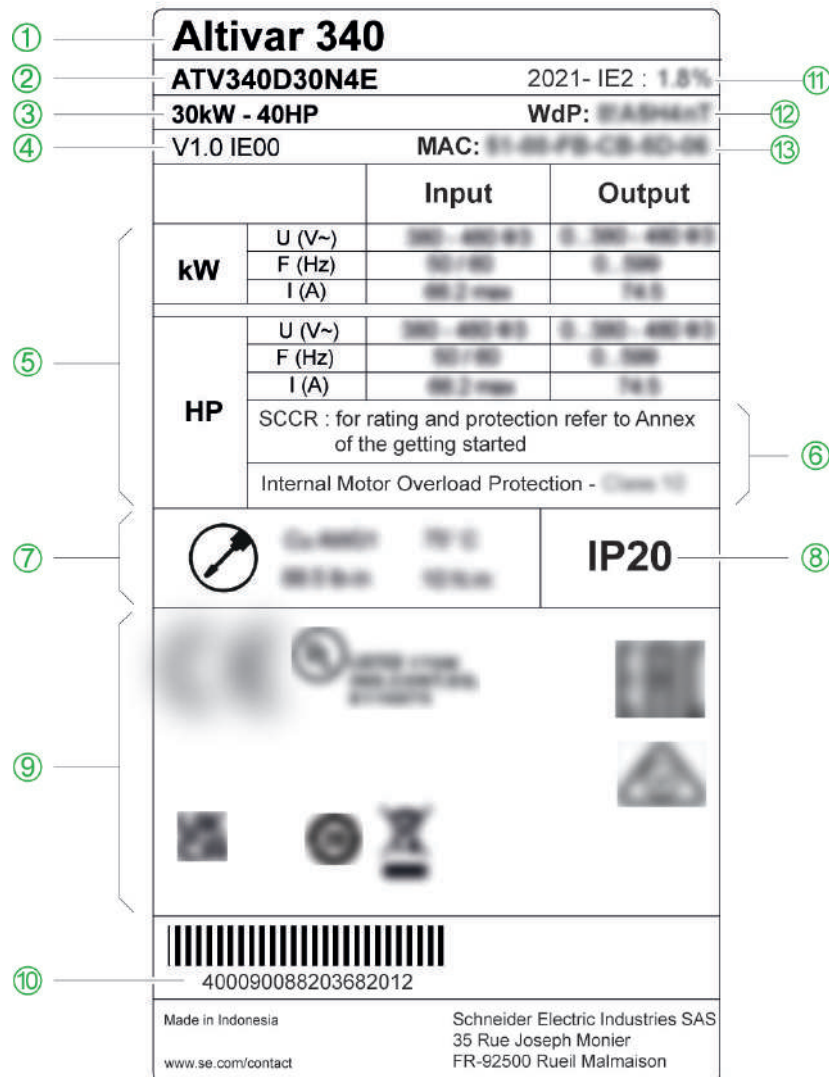

- ① Product type
- ② Catalog number
- ③ Power rating
- ④ Firmware version
- ⑤ Power part data input, output
- ⑥ Fuses and overload protection information
- ⑦ Power part cable information
- ⑧ Degree of protection
- ⑨ Certifications
- ⑩ Serial number
- ⑪ Ecodesign regulation code
- ⑫ Webserver default password (\*)
- ⑬ MAC address (\*)

(\*)

- Also refer to the programming manual.
- If the Nameplate is not visible after the drive mounting phase, note or take a photo of the webserver default password.

## Manufacturing Date

Use the serial number ⑩ of the drive to retrieve its manufacturing date.

The four digits before the last 5 characters of the serial number provide respectively the year and the week of manufacture.

In the nameplate example illustrated above **40009008A213682012** the manufacturing date is year 2021, week 36.

## Manufacturing Plant

Use the serial number ⑩ of the drive to retrieve its manufacturing plant.

The two digits after the first 7 characters of the serial number provide respectively the manufacturing plant.

In the nameplate example illustrated above **40009008A213682012** the manufacturing plant is 8A.

# Accessories and Options

## Introduction

The Altivar Machine ATV340 drives are designed to take numerous accessories and options to increase their functionality. For a detailed description and catalog numbers, refer to the Catalog on [www.se.com](http://www.se.com)

All accessories and options come with an instruction sheet to help installation and commissioning. Therefore you will only find here a short product description.

## Accessories

### Drive

- Fan replacement kit
- EMC kits
- Connector kits for I/O, motor and power connection
- Control cables
- Daisy chain DC bus sharing cable

### Display terminals

- Plain Text Display Terminal for direct or remote mounting (VW3A1113)
- Graphic Display Terminal (VW3A1111) with a cable (frame sizes 1...3), for extended mounting
- Remote mounting kit for mounting on enclosure door
- Multidrop connection accessories for connecting several drives to the RJ45 terminal port

### Drive mounting kits

- Flush mounting kit, page 68 for separate air flow

### Modbus Communication tools

- Wi-Fi dongle
- Bluetooth dongle
- USB to Modbus adapter

## Options

### Encoder interface modules

- Resolver encoder interface module
- Digital interface encoder module 5/12 V
- Analog interface encoder module

**Additional Module Support** for frame sizes 4 and 5 (slot C) , page 21

### Safety functions module

#### I/O extension modules

- Digital and analog I/O module
- Relay output module

#### Communication modules

- CANopen daisy chain
- CANopen SUB-D
- CANopen screw terminal block
- PROFINET
- PROFIBUS DP V1
- DeviceNet
- EtherCAT

### Braking resistors

### Mains Chokes

### EMC filters

# Display Terminals

## Introduction

The drive is compatible with the Plain Text Display Terminal (VW3A1113) or with the Graphic Display Terminal (VW3A1111). These display terminals can be ordered separately.

Refer to the ATV340 programming manual for further operation details.

## Description of the Plain Text Display Terminal (VW3A1113)

The Plain Text Display Terminal is a local control unit which can be either plugged on the drive or mounted on the door of an enclosure with its dedicated door mounting kit (VW3A1114).

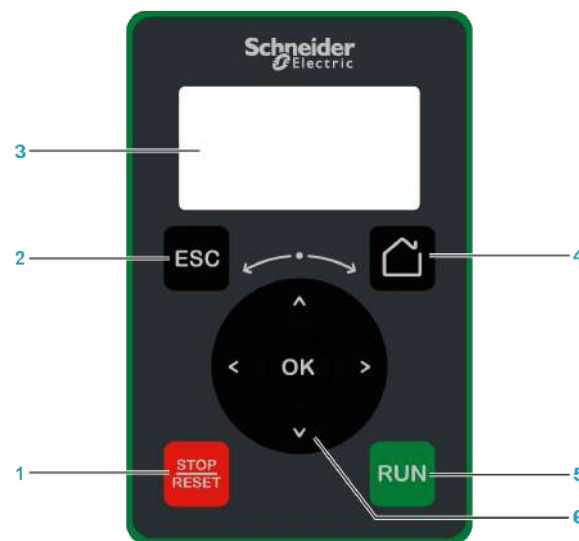

**1 STOP / RESET:** Stop command / apply a Fault Reset.

**2 ESC:** used to quit a menu/parameter or remove the currently displayed value in order to revert to the previous value retained in the memory

**3 Graphic display.**

**4 Home:** access directly the home page.

**5 RUN:** executes the function assuming it has been configured.

**6 Touch wheel / OK:** used to save the current value or access the selected menu/parameter. It also allows to access more details on the displayed error codes. The touch wheel is used to scroll fast into the menus. Up/down arrows are used for precise selections, right/left arrows are used to select digits when setting a numerical value of a parameter.

**NOTE:** Keys 1, 5 and 6 can be used to control the drive if control via the Display Terminal is activated. To activate the keys on the Display Terminal, you first need to set **[Ref Freq 1 Config] FR1** to **[HMI] LCC**.

## Description of the Graphic Display Terminal (VW3A1111)

The Graphic Display Terminal is a local control unit which can be mounted on the door of an enclosure with its dedicated door mounting kit (VW3A1112). The Graphic Display Terminal embeds a real-time clock used for the time stamping of logged data and all other functions which require time information.

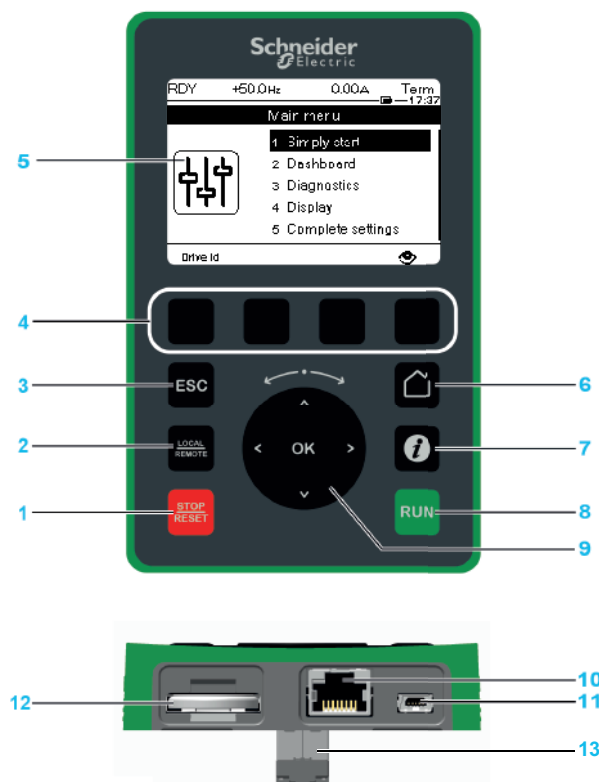

**1 STOP / RESET:** Stop command / apply a Fault Reset.

**2 LOCAL / REMOTE:** used to switch between local and remote control of the drive.

**3 ESC:** used to quit a menu/parameter or remove the currently displayed value in order to revert to the previous value retained in the memory

**4 F1 to F4:** function keys used to access drive id, QR code, quick view, and submenus. Simultaneous press of F1 and F4 keys generates a screenshot file in the Graphic Display Terminal internal memory.

**5 Graphic display.**

**6 Home:** used to access directly at the home page.

**7 Information:** used to have more information about parameters. The selected parameter code is displayed on the first line of the information page.

**8 RUN:** executes the function assuming it has been configured.

**9 Touch wheel / OK:** used to save the current value or access the selected menu/parameter. The touch wheel is used to scroll fast into the menus. Up/down arrows are used for precise selections, right/left arrows are used to select digits when setting a numerical value of a parameter.

**10 RJ45 Modbus serial port:** used to connect the Graphic Display Terminal to the drive in remote control.

**11 Mini-B USB port:** used to connect the Graphic Display Terminal to a computer.

**12 Battery** (10 years service life. Type: CR2032). The battery positive pole points to the front face of the Graphic Display Terminal .

**13 RJ45 male connector:** used to plug the Display Terminal on the Altivar or the door mounting kit. .

**NOTE:** Keys 1, 8 and 9 can be used to control the drive if control via the Display Terminal is activated. To activate the keys on the Display Terminal, you first need to set **[Ref Freq 1 Config] FR1** to **[HMI] LCC**.

## Graphic Display Terminal Connected to a Computer

<b>NOTICE</b>
<b>INOPERATIVE EQUIPMENT</b>
Do not connect equipment to the RJ45 port and to the USB port of the Graphic Display Terminal at the same time.
<b>Failure to follow these instructions can result in equipment damage.</b>

## How to customize the logo displayed at power on of the Graphic Display Terminal?

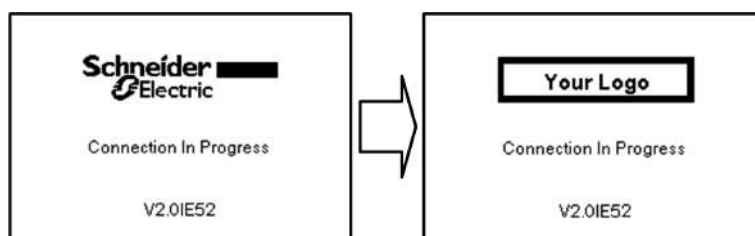

From the firmware version V2.0 of the Graphic Display Terminal, the logo displayed at power on by the Graphic Display Terminal can be customized. By default, the Schneider-Electric logo is displayed.

To modify the displayed logo, you must:

- Create your own logo and save it as a bitmap file (.bmp) with the name logo\_init. The logo must be saved in black & white and the dimensions must be 137x32 pixels.
- Connect the Graphic Display Terminal to a computer via an USB cable.
- Copy your logo (logo\_init.bmp) in the folder KPCONFIG of the Graphic Display Terminal.

At next power on of the Graphic Display Terminal connected to the drive, your own logo should be displayed.

If the logo of Schneider-Electric is still displayed, verify the characteristics of your file and the location where it has been copied.

## SoMove



SoMove is a setup software for PC designed to configure Schneider Electric motor control devices. It incorporates functions for device setup, monitoring, fieldbus management and maintenance via an user-friendly interface.

To download SoMove go to [SoMove FDT](#).

To download the required DTM ATV340: [DTM](#).

A contextual help for SoMove is available by pressing F1 on the keyboard.

# Altivar Efficiency Calculator

## Description

This tool calculates the level of energy efficiency of your variable speed drive according to the Ecodesign standard EN/IEC 61800-9-2.

In 2 specific cases :

- **Drive Efficiency** (CDM Complete Drive Module) :  
Performance is determined according to 8 operating points taking into account torque and speed.
- **System Efficiency** (PDS Power Drive System) :  
This includes the efficiency of the variable speed drive and its motor.  
Performance is determined according to 8 operating points taking into account torque and speed.

## Easy access to the tool

The tool is available at the address: [altivar-efficiency-calculator.se.app](http://altivar-efficiency-calculator.se.app)

# Steps for Setting Up the Drive

## INSTALLATION

### 1 Receive and inspect the drive controller

- Check that the catalog number printed on the label is the same as that on the purchase order.
- Remove the drive from its packaging and check that it has not been damaged.

### 2 Verify the supply mains

- Verify that the supply mains is compatible with the power part supply range of the drive.

### 3 Mount the drive

- Mount the drive in accordance with the instructions in this document.
- Install the transformer(s), if any.
- Install any internal and external options.

### 4 Wire the drive

- Connect the motor, ensuring that its connections correspond to the voltage.
- Connect the supply mains, after making sure that the power is off.
- Connect the control.

Steps 1 to 4 must be performed with the power off.



## 5 PROGRAMMING

Refer to the Programming Manual

# Preliminary Instructions

## Verify the Delivery of the Drive

Damaged products or accessories may cause electric shock or unanticipated equipment operation.

### **DANGER**

#### **ELECTRIC SHOCK OR UNANTICIPATED EQUIPMENT OPERATION**

Do not use damaged products or accessories.

**Failure to follow these instructions will result in death or serious injury.**

Contact your local Schneider Electric sales office if you detect any damage whatsoever.

Step	Action
1	Remove the drive from the packaging and verify that it has not been damaged
2	Verify that the catalog number printed on the nameplate corresponds to the purchase order.

## Handling and Storage

### **WARNING**

#### **INCORRECT HANDLING**

- Lifting and handling must be performed by qualified personnel in accordance with the requirements of the site and in compliance with all pertinent regulations.
- Verify that there are no persons or obstructions in the area of operation of the lifting and handling equipment.
- Use lifting and handling equipment appropriate for the load and take all necessary measures to avoid swinging, inclination, toppling and any other potentially hazardous conditions.
- Follow all handling instructions provided in this manual and in all associated product documentation.
- Take all measures required to avoid damage to the product and other hazards when handling or opening the packaging.
- Handle and store the product in its original packaging.
- Do not handle and store the product if the packaging is damaged or appears to be damaged.

**Failure to follow these instructions can result in death, serious injury, or equipment damage.**

To help protect the product before installation, handle and store it in its packaging.

Ensure that the specified ambient conditions are followed.

## Handling the Drive

The drives of frame sizes 1, 2 and 3 can be removed from their packaging and installed without a handling device.

The drives of frame sizes 4 and 5 require a handling device; for this reason, these drives include lifting lugs.

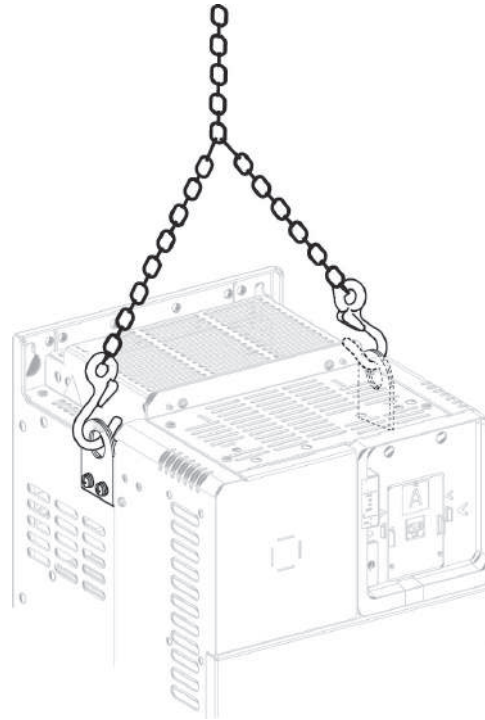

# Technical Data

## What's in This Part

Mechanical Data .....	37
Electrical Data - Drive Ratings and Braking Resistors.....	48
Electrical Data - Upstream Protective Device.....	54

# Mechanical Data

## What's in This Chapter

Environmental Conditions .....	38
Dimensions and Weights .....	40

## Environmental Conditions

### Withstand to harsh environments

- Storage short time and transportation: 2C1, conforming to IEC/EN 60721-3-2
- Storage long time: 1C1, Conforming to IEC/EN 60721-3-1
- Chemical class: 3C3, conforming to IEC/EN 60721-3-3
- Mechanical class: 3S3, conforming to IEC/EN 60721-3-3

### Climatic Environmental Conditions for Storage and Transportation

Ambient air temperature for all frame sizes: -40...70 °C, -40...158 °F

**NOTE:**

- The environment during transport and storage must be dry and dust-free.
- The bearing and transport temperature must remain within the specified range.

### Relative Humidity

Without dripping water and without condensation: 5...95%

### Climatic Environmental Conditions for Operation

The maximum permissible ambient temperature during operation depends on the mounting distances between the devices and on the required power. Observe the pertinent instructions in the chapter [Drive Mounting](#), page 65.

**NOTE:** The drive is designed to be used in a controlled indoor environment.

#### Ambient Air Temperature Ranges

Drive frame Size	Temperature in Normal Duty		Temperature in Heavy Duty		Comments
	°C	°F	°C	°F	
1, 2 and 3	°C	-15...40	°C	-15...50	Without derating
	°F	5...104	°F	5...122	
	°C	40...50	°C	50...60	With derating
	°F	104...122	°F	122...140	
4 and 5	°C		°C	-15...50	Without derating
	°F		°F	5...122	
	°C		°C	50...60	With derating
	°F		°F	122...140	

## Operating Altitude

Operating possibilities according to the altitude.

The altitude is given for the installation height above mean sea level.

### Frame Size 1 to 3

Altitude	Derating	Maximum ambient temperature
Up to 1000 m (3300 ft)	o	60°C
1000...2000 m (3300...6600 ft)	✓	45°C
2000...3000 m (6600...9840 ft)	✓	40°C
<b>Legend:</b>		
✓: Derate the nominal current of the drive by 1% for each additional 100 m.		
o: Without derating		

### Frame Size 4 and 5

Altitude	Derating	Supply Electrical Network		
		TT/TN	IT	Corner-Grounded
Up to 1000 m (3300 ft)	o	Yes	Yes	Yes
1000...2000 m (3300...6600 ft)	✓	Yes	Yes	Yes
2000...3800 m (6600...12400 ft)	✓	Yes	Yes	No
3800...4800 m (12400...15700 ft)	✓	Yes	No	No
<b>Legend:</b>				
✓: Derate the nominal current of the drive by 1% for each additional 100 m.				
o: Without derating				

## Pollution Degree and Degree of Protection

- Degree of Pollution: 2
- Degree of Protection: IP20

# Dimensions and Weights

## About the drawings

All drawings CAD files can be downloaded from [www.se.com](http://www.se.com)

**NOTE:** The dimensions below do not include:

- A depth increase when using the optional plain text display terminal.
- On frame sizes 1, 2 and 3, a 50 mm (2 in.) distance for appropriate front control wiring,
- On frame sizes 4 and 5, a depth increase of 30 mm (1.2 in.) if using the additional slot option, or 50 mm (2 in.) if using the option together with the graphic display terminal. This option module takes place between the graphic display terminal and the drive, causing the depth value to be increased. It enables to connect a safety output module, an I/O or relay output module.

# Frame Size 1

## ATV340U07N4•... ATV340U40N4•

mm  
in.

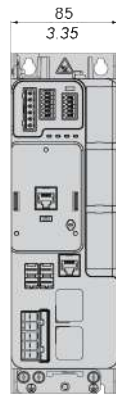

mm  
in.

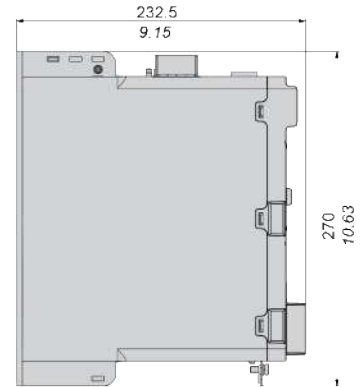

mm  
in.



### Weights

Catalog Number	Weight in kg (lb)
ATV340U07N4•, ATV340U15N4•	1.7 (3.7)
ATV340U22N4•	1.8 (4)
ATV340U30N4	2.1 (4.6)
ATV340U30N4E, ATV340U40N4	2.2 (4.8)
ATV340U40N4E	2.3 (5.1)

## Frame Size 2

### ATV340U55N4• and U75N4•

mm  
in.

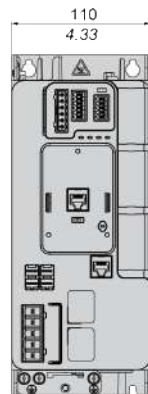

mm  
in.

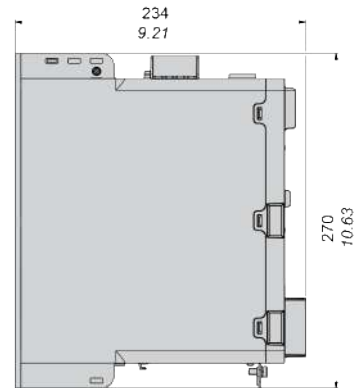

mm  
in.

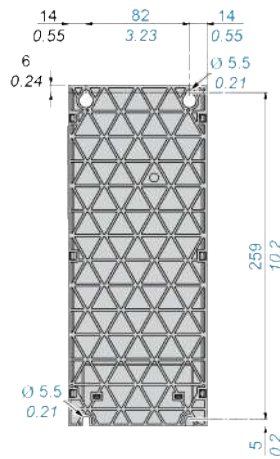

### Weights

Catalog Number	Weight in kg (lb)
ATV340U55N4•	2.9 (6.4)
ATV340U75N4•	3 (6.6)

# Frame Size 3

## ATV340D11N4•... ATV340D22N4•

mm  
in.

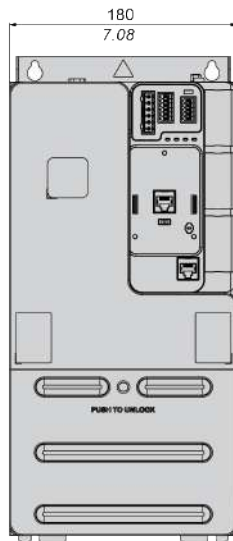

mm  
in.

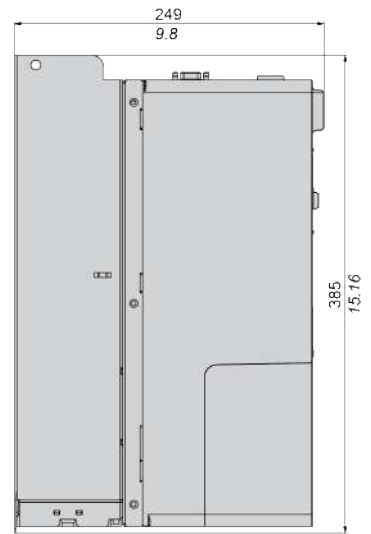

mm  
in.

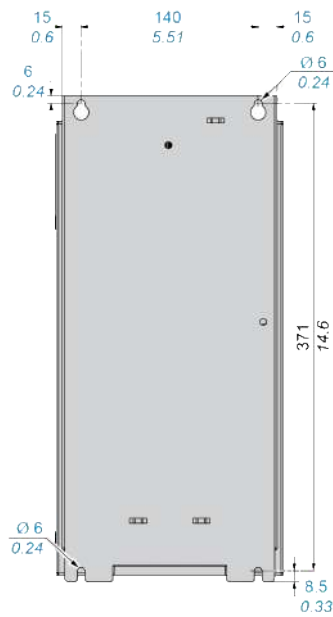

### Weights

Catalog Number	Weight in kg (lb)
ATV340D11N4•, ATV340D15N4•	9.5 (20.9)
ATV340D18N4•, ATV340D22N4•	10.2 (22.5)

# Frame Size 4

## IP20 Drives - ATV340D30N4E... ATV340D37N4E

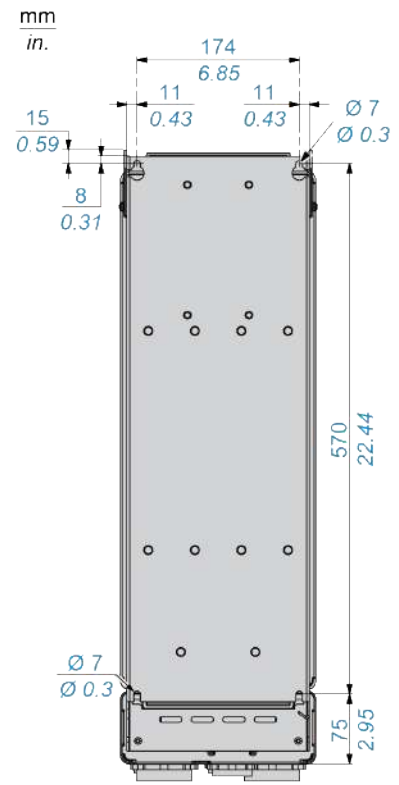
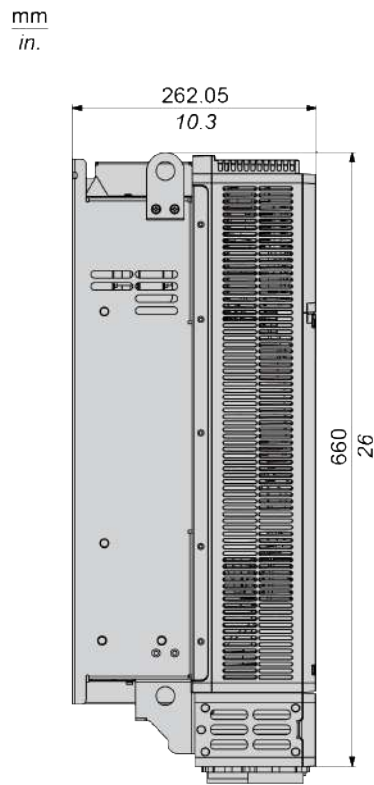
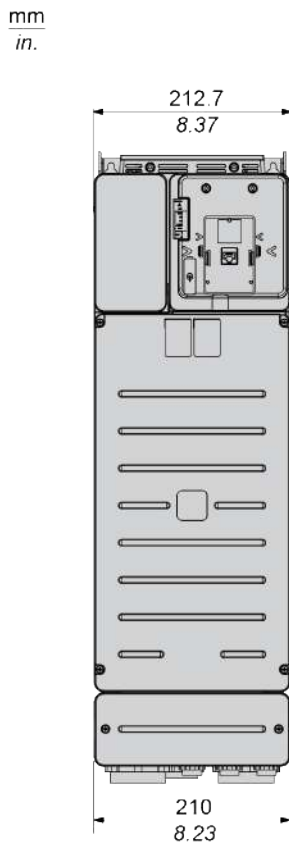

Catalog Number	Weight in kg (lb)
ATV340D30N4E	27.9 (61.5)
ATV340D37N4E	28.4 (62.6)

**IP20 Drives - ATV340D30N4EZ•... ATV340D37N4EZ•, except on Lower Part side (IP00) - Front, Side And Rear View**

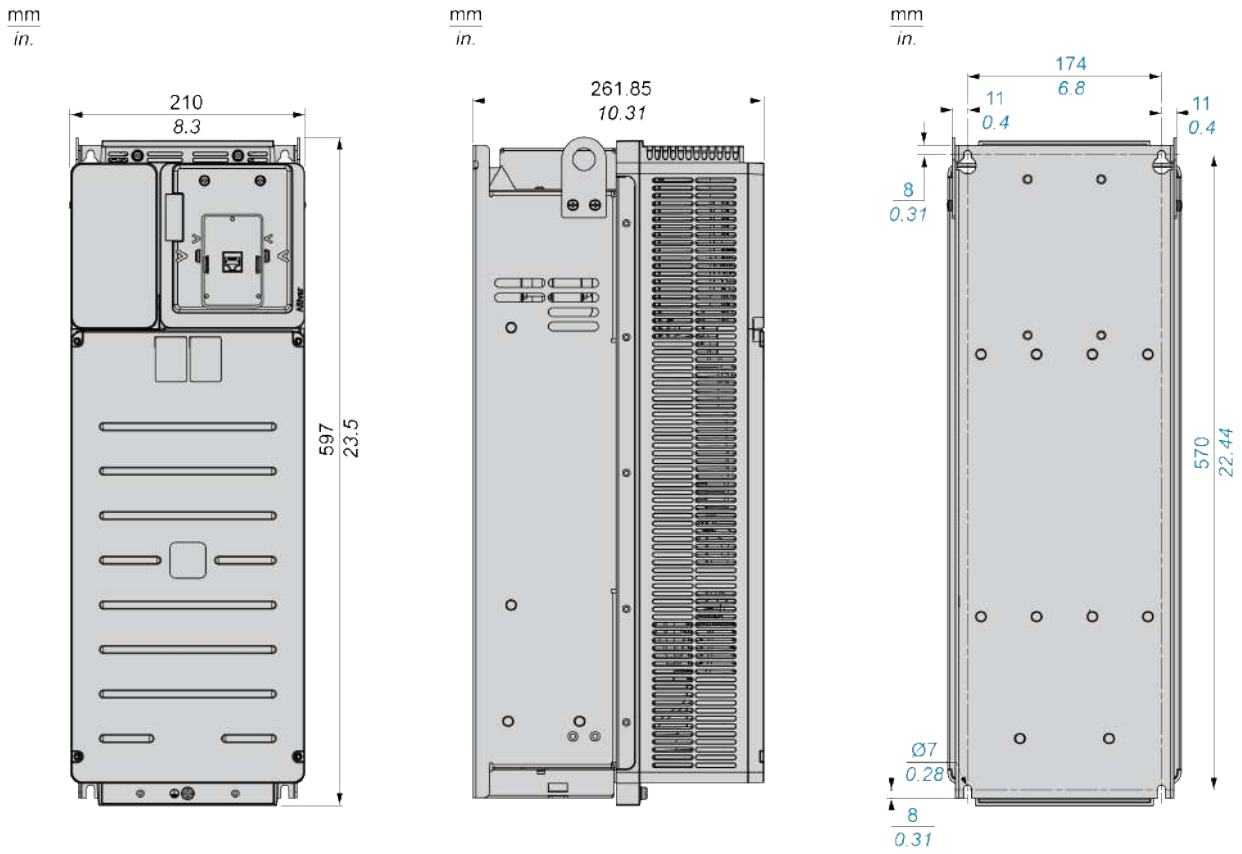

**Weights**

Catalog Number	Weight in kg (lb)
ATV340D30N4EZ•	25 (55.1)
ATV340D37N4EZ•	26 (57.3)

# Frame Size 5

## IP20 Drives ATV340D45N4E...ATV340D75N4E

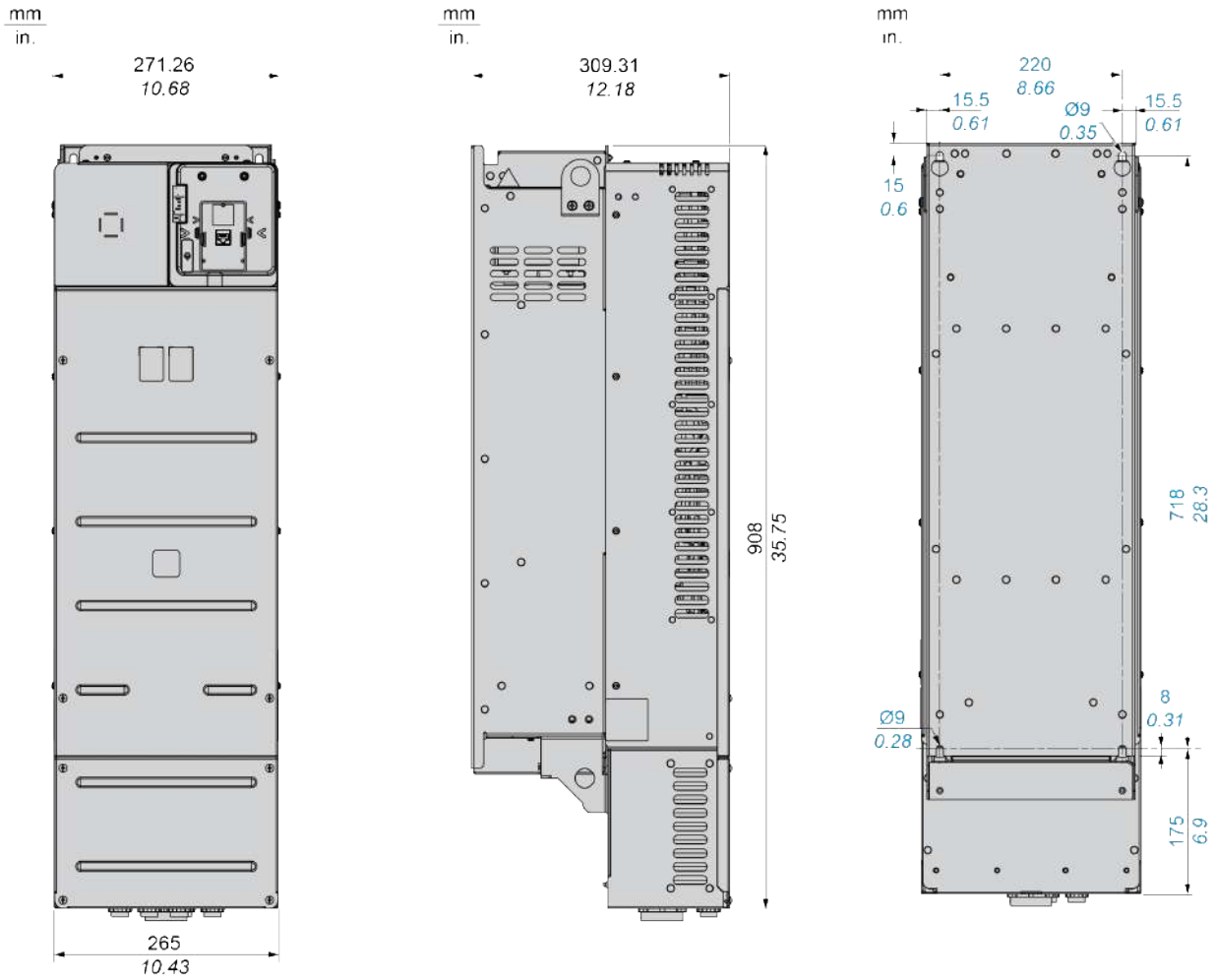

Catalog Number	Weight in kg (lb)
ATV340D45N4E	56.4 (124.3)
ATV340D55N4E	57.9 (127.6)
ATV340D75N4E	58.4 (128.7)



# Electrical Data - Drive Ratings and Braking Resistors

## What's in This Chapter

Drive Ratings in Normal Duty .....	49
Drive Ratings in Heavy Duty .....	51
Braking Resistors .....	53

# Drive Ratings in Normal Duty

## Applications

Altivar Machine variable speed drives are designed for use in two operating modes Heavy duty, page 51 and Normal duty. This enables to optimize the drive nominal rating according to the system constraints (3-Phase 380 (-15%)...480 (+10%) Vac 50/60 Hz).

Normal duty (ND): Dedicated mode for applications requiring a slight overload (up to 110%) with a motor power one rating higher than the drive nominal power

**NOTE:**

- For fuse and circuit-breaker ratings refer to the information provided in the Altivar Machine ATV340 Getting Started Annex (SCCR) NVE37641 for UL/CSA compliance and also in the catalog for IEC compliance.
- For motor overload and drive thermal monitoring functions, refer to the Programming manual.

**NOTE:**

- At maximum ambient temperature of 40°C (104 °F), use of a mains choke is required for drive frame size 1, 2 and 3.
- At maximum ambient temperature of 50°C (122 °F) for drive frame size 4 and 5.

## Power Part Supply Ratings

Catalog Number	Nominal Power		Power Part Supply				
			Nominal Input Current (1)		Required min. mains choke	Current Harmonics with min. choke, THDi	Max. Inrush Current (2)
			At 380 Vac	At 480 Vac			
kW	HP	A	A	mH	%	A	
ATV340U07N4•	1.1	1.5	2.6	2.1	2	94	8.7
ATV340U15N4•	2.2	3	5.1	4.1	2	77	8.7
ATV340U22N4•	3	3	6.6	5.3	1.47	80	8.7
ATV340U30N4•	4	5	8.6	6.8	1.1	80	36.1
ATV340U40N4•	5.5	7	11.4	9.0	0.8	79	36.1
ATV340U55N4•	7.5	10	15.3	12.2	0.58	82	45.3
ATV340U75N4•	11	15	22.0	17.7	0.4	83	45.3
ATV340D11N4•	15	20	28.8	23.0	0.3	82	80.8
ATV340D15N4•	18.5	25	37.4	30.2	0.24	81	80.8
ATV340D18N4•	22	30	43.4	35.0	0.2	81	60.6
ATV340D22N4•	30	40	60.1	48.6	0.15	80	60.6
ATV340D30N4E•	37	50	66.2	57.3	–	< 48	92
ATV340D37N4E•	45	60	79.8	69.1	–	< 48	110
ATV340D45N4E•	55	75	97.2	84.2	–	< 48	176
ATV340D55N4E•	75	100	131.3	112.7	–	< 48	187
ATV340D75N4E•	90	125	156.2	135.8	–	< 48	236
(1)	Drives of frame size 4 and 5 use an integrated DC choke, therewith the mains current harmonics and the mains current are reduced.						
(2)	Peak current when power is switched on, for the maximum supply mains voltage.						

## Power Part Output Ratings

Catalog Number	Nominal Power		Drive Power Part Output			
			Nominal Current (1)		Maximum transient current	
			At 380 Vac	At 480 Vac	60 s (2)	2 s (3)
	kW	HP	A	A	A	A
ATV340U07N4•	1.1	1.5	2.8	2.6	3.1	3.8
ATV340U15N4•	2.2	3	5.6	4.8	6.2	7.6
ATV340U22N4•	3	3	7.2	6.8	7.9	9.7
ATV340U30N4•	4	5	9.3	7.6	10.2	12.6
ATV340U40N4•	5.5	7	12.7	11	14	17.1
ATV340U55N4•	7.5	10	16.5	14	18.2	22.3
ATV340U75N4•	11	15	24	21	26.4	32.4
ATV340D11N4•	15	20	32	27	35.2	43.2
ATV340D15N4•	18.5	25	39	34	42.9	52.7
ATV340D18N4•	22	30	46	40	50.6	62.1
ATV340D22N4•	30	40	62	52	68.2	83.7
ATV340D30N4E•	37	50	74.5		89.4	not allowed
ATV340D37N4E•	45	60	88		105.6	
ATV340D45N4E•	55	75	106		127.2	
ATV340D55N4E•	75	100	145		174	
ATV340D75N4E•	90	125	173		207.6	
(1)	The switching frequency is adjustable from: <ul style="list-style-type: none"> <li>• 2...16 kHz for drive frame sizes 1...3, rated value: 4 kHz</li> <li>• 2...12 kHz for drive frame size 4, rated value: 4 kHz</li> <li>• 2...8 kHz for drive frame size 5, rated value: 2.5 kHz</li> </ul> For operation at switching frequencies higher than the rated value. Derating must be applied to the drive (output) current, page 73. In this case, switching frequency can be reduced if an excessive temperature rise occurs.					
(2)	The drive is designed to run up to 60 s at 110% of nominal current for frame sizes 1, 2 and 3. The drive is designed to run up to 60 s at 120% of nominal current for frame sizes 4 and 5.					
(3)	The drives of frame sizes 1...3 are designed to run up to 2 s at 135% of nominal current.					

# Drive Ratings in Heavy Duty

## Applications

Altivar Machine variable speed drives are designed for use in two operating modes Heavy duty and Normal duty, page 49. This enables to optimize the drive nominal rating according to the system constraints (3-Phase 380 (-15%)...480 (+10%) Vac 50/60 Hz).

Heavy duty (HD) is a dedicated mode for applications requiring a significant overload (up to 150%) with a motor power identical to the drive nominal power

### NOTE:

- For fuse and circuit-breaker ratings refer to the information provided in the Altivar Machine ATV340 Getting Started Annex (SCCR) NVE37641 for UL/CSA compliance and also in the catalog for IEC compliance.
- For motor overload and drive thermal monitoring functions, refer to the Programming manual.

## Power Part Supply Ratings

Catalog Number	Nominal Power		Power Part Supply			
			Nominal Input Current (1)		Maximum prospective line Isc (2)	Max. Inrush Current (3)
	At 380 Vac	At 480 Vac	kA	A		
	kW	HP	A	A	kA	A
ATV340U07N4•	0.75	1	3.4	2.6	5	8.7
ATV340U15N4•	1.5	2	6	4.9	5	8.7
ATV340U22N4•	2.2	3	8.4	6.6	5	8.7
ATV340U30N4•	3	3	10.7	8.5	5	36.1
ATV340U40N4•	4	5	13.4	10.6	5	36.1
ATV340U55N4•	5.5	7	20	16	22	45.3
ATV340U75N4•	7.5	10	25.6	20.4	22	45.3
ATV340D11N4•	11	15	34.7	27.7	22	80.8
ATV340D15N4•	15	20	44.9	35.7	22	80.8
ATV340D18N4•	18.5	25	54.7	43.4	22	60.6
ATV340D22N4•	22	30	63.5	50.6	22	60.6
ATV340D30N4E	30	40	54.8	48.3	50	92
ATV340D37N4E	37	50	67.1	59	50	110
ATV340D45N4E	45	60	81.4	71.8	50	176
ATV340D55N4•	55	75	98.9	86.9	50	187
ATV340D75N4•	75	100	134.3	118.1	50	236
(1)	Drive frame size 4, 5 uses an integrated DC choke, therewith the mains current harmonics and the mains current are reduced.					
(2)	The drive is designed for a corresponding line supply. If the Isc is higher a mains choke must be used. Isc: Short circuit current. See the Annex to the Getting Started (NVE37641) for UL Short Circuit Current Ratings (SCCR) values. The products of frame sizes 1, 2 and 3 have no means integrated to reduce the mains current harmonics. The THDi is > 120%. If lower harmonics are required use a mains choke.					
(3)	Peak current when power is switched on, for the maximum supply mains voltage.					

## Power Part Output Ratings

Catalog Number	Nominal Power		Drive Power Part Output			
			Nominal Current (1)		Maximum transient current	
			At 380 Vac	At 480 Vac	60 s (2)	2 s (3)
	kW	HP	A	A	A	A
ATV340U07N4•	0.75	1	2,2	2,1	2,1	3,3
ATV340U15N4•	1.5	2	4	3,4	3,4	6
ATV340U22N4•	2.2	3	5,6	4,8	4,8	8
ATV340U30N4•	3	3	7,2	6,2	6,2	11
ATV340U40N4•	4	5	9,3	7,6	7,6	14
ATV340U55N4•	5.5	7	12,7	11	11	19,1
ATV340U75N4•	7.5	10	16,5	14	14	24,8
ATV340D11N4•	11	15	24	21	21	36
ATV340D15N4•	15	20	32	27	27	48
ATV340D18N4•	18.5	25	39	34	34	59
ATV340D22N4•	22	30	46	40	40	69
ATV340D30N4E•	30	40	61,5	not allowed	92,3	not allowed
ATV340D37N4E•	37	50	74,5		111,8	
ATV340D45N4E•	45	60	88		132	
ATV340D55N4E•	55	75	106		159	
ATV340D75N4E•	75	100	145		217,5	
(1)	<p>The switching frequency is adjustable from:</p> <ul style="list-style-type: none"> <li>• 2...16 kHz for drive frame sizes 1...3, rated value: 4 kHz</li> <li>• 2...12 kHz for drive frame size 4, rated value: 4 kHz</li> <li>• 2...8 kHz for drive frame size 5, rated value: 2.5 kHz</li> </ul> <p>For operation at switching frequencies higher than the rated value. Derating must be applied to the drive (output) current, page 73. In this case, switching frequency can be reduced if an excessive temperature rise occurs.</p>					
(2)	<p>The drive is designed to run up to 60 s at 110% of nominal current for frame sizes 1, 2 and 3.</p> <p>The drive is designed to run up to 60 s at 120% of nominal current for frame sizes 4 and 5.</p>					
(3)	<p>The drives of frame sizes 1...3 are designed to run up to 2 s at 135% of nominal current.</p>					

# Braking Resistors

## General

Braking resistors allow the drives to operate while braking to a standstill or during slowdown braking, by dissipating the braking energy. They enable maximum transient braking torque.

- For a detailed description and catalog numbers, refer to the [catalog](#).
- For mounting instructions, wiring diagrams and other information, refer to the instruction sheet NHA87388 supplied with the resistor and available on [www.se.com](http://www.se.com).

**⚠ DANGER**

**HAZARD OF FIRE**

- Some braking resistors are equipped with a thermal switch to detect overheating of the resistor. This thermal switch must be used upstream to the drive to switch off the mains contactor in case of overheating detection (1).
- When a braking resistor from third party supplier is used, conduct your own risk assessment according to EN ISO 12100 and all other standards that apply to your application to ensure that any failure mode does not result in unsafe conditions. For example, but not limited to, thermal monitoring must be used to switch off the mains contactor and/or the braking resistor itself in case of overheating detection.

**Failure to follow these instructions will result in death or serious injury.**

(1) Refer to the wiring diagrams provided into the braking resistors instruction sheet NHA87388. This instruction sheet is delivered with the braking resistor and/or can be downloaded on [www.se.com](http://www.se.com).

## Minimum Resistor Values

Minimum allowed value of the resistor to be connected

Catalog Number	Minimum Value in $\Omega$
ATV340U07N4•	78
ATV340U15N4•	56
ATV340U22N4•	52
ATV340U30N4•	34
ATV340U40N4•	31
ATV340U55N4•	31
ATV340U75N4•	28
ATV340D11N4•	16

Catalog Number	Minimum Value in $\Omega$
ATV340D15N4•	16
ATV340D18N4•	15
ATV340D22N4•	10
ATV340D30N4E•	10
ATV340D37N4E•	10
ATV340D45N4E•	2.5
ATV340D55N4E•	2.5
ATV340D75N4E•	2.5

# Electrical Data - Upstream Protective Device

## What's in This Chapter

Upstream Protective Device – Introduction .....	55
Prospective Short-Circuit Current .....	57
IEC Type Circuit-Breaker — with enclosure .....	60
IEC Fuses — with enclosure .....	62
UL Circuit-Breakers and Fuses .....	64

# Upstream Protective Device – Introduction

## Overview

⚠⚠ DANGER
<p><b>INSUFFICIENT PROTECTION AGAINST OVERCURRENTS CAN CAUSE FIRE OR EXPLOSION</b></p> <ul style="list-style-type: none"> <li>• Use properly rated overcurrent protection devices.</li> <li>• Use the fuses/circuit breakers specified.</li> <li>• Do not connect the product to a supply mains whose prospective short circuit current rating (current that flows during a short circuit) exceeds the specified maximum permissible value.</li> <li>• When rating the upstream mains fuses and the cross sections as well as the lengths of the mains cables, take into account the minimum required prospective short-circuit current (Isc). Refer to the Upstream Protection Device section.</li> <li>• If the minimum required prospective short-circuit current (Isc) is not available, increase the power of the transformer or decrease the length of the cables.</li> </ul> <p><b>Failure to follow these instructions will result in death or serious injury.</b></p>

The values and products for IEC compliance are specified in the present manual.

The values and products for UL/CSA compliance are specified in the ATV340 Getting Started Annex NVE37643 provided with the product.

## General

- The Short Circuit Protective Device (SCPD) rated to the drive will help protect the upstream installation in case of a short-circuit internal to the drive and mitigate the damage to the drive and its surrounding area.
- The SCPD rated to the drive is mandatory to help ensuring the safety of the Power Drive System.  
It comes in addition to the upstream branch circuit protection which is in compliance with the local regulation for electrical installation.
- The SCPD shall mitigate the damage in case of detected error condition such as an internal short-circuit of the drive.
- The SCPD must take into account both following characteristics...
  - a maximum prospective short-circuit current
  - a minimum required prospective short-circuit current (Isc).

If the minimum required prospective short-circuit current (Isc) is not available, increase the power of the transformer or decrease the length of the cables

In other cases, contact your Schneider Electric Customer Care Center (CCC) [www.se.com/CCC](http://www.se.com/CCC) for specific selection of Short Circuit Protective Device (SCPD).

**Note:** The electronic power output short-circuit protection circuitry meets the requirements of IEC 60364-4-41:2005/AMD1 — Clause 411.

## Wiring Diagram

This diagram shows an example of installation with both SCPD types, Circuit-breaker and Fuse link rated to the drive.

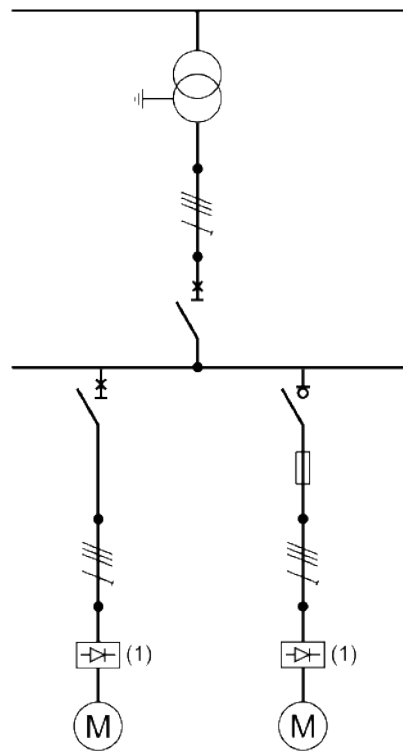

(1) Drive

# Prospective Short-Circuit Current

## Calculation

The prospective short-circuit current shall be computed at the drive connection points.

We recommend using the Schneider Electric tool Ecodial Advance Calculation



available on [www.se.com/en/product-range-presentation/61013-ecodial-advance-calculation/](http://www.se.com/en/product-range-presentation/61013-ecodial-advance-calculation/)

The following equations allow to estimate the value of the symmetrical three-phase prospective short-circuit current ( $I_{sc}$ ) at the drive connection points.

$$X_t = \frac{U^2}{S_n} \cdot usc$$

$$Z_{cc} = \sqrt{\left(\rho \cdot \frac{l}{S} + R_f\right)^2 + (X_t + X_c \cdot l + X_f)^2}$$

$$I_{sc} = \frac{U}{\sqrt{3}} \cdot \frac{1}{Z_{cc}}$$

<b><math>I_{sc}</math></b>	Symmetrical three-phase prospective short-circuit current (kA)
<b><math>X_t</math></b>	Transformer reactance
<b><math>U</math></b>	No-load phase to phase voltage of the transformer (V)
<b><math>S_n</math></b>	Apparent transformer power (kVA)
<b><math>usc</math></b>	Short-circuit voltage, according to the transformer data sheet (%)
<b><math>Z_{cc}</math></b>	Total short-circuit impedance (mΩ)
<b><math>\rho</math></b>	Conductor resistivity e.g. Cu: 0.01851 mΩ.mm
<b><math>l</math></b>	Conductor length (mm)
<b><math>S</math></b>	Conductor cross section (mm <sup>2</sup> )
<b><math>X_c</math></b>	Conductor lineic reactance (0.0001 mΩ/mm)
<b><math>R_f, X_f</math></b>	Resistance and reactance of the line filter (mΩ) , page 59

## Example of Calculation with Copper Cable (without line filter)

Transformer 50 Hz	U 400 Vac Usc	Cable Cross Section	Isc depending on cable length in m(ft)							
			10 (33)	20 (66)	40 (131)	80 (262)	100 (328)	160 (525)	200 (656)	320 (1,050)
kVA	%	mm <sup>2</sup> (AWG)	kA	kA	kA	kA	kA	kA	kA	kA
100	4	2.5 (14)	2.3	1.4	0.8	0.4	0.3	0.2	0.2	0.1
		4 (12)	2.9	2.0	1.2	0.6	0.5	0.3	0.2	0.2
		6 (10)	3.2	2.6	1.6	0.9	0.7	0.5	0.4	0.2
		10 (8)	3.4	3.1	2.3	1.4	1.2	0.8	0.6	0.4
		25 (4)	3.5	3.4	3.1	2.5	2.2	1.6	1.4	0.9
		50 (0)	3.5	3.5	3.3	3.0	2.8	2.3	2.1	1.5
		70 (00)	3.5	3.5	3.4	3.1	2.9	2.6	2.3	1.8
		120 (250 MCM)	3.6	3.5	3.4	3.2	3.1	2.8	2.6	2.1
250	4	6 (10)	5.7	3.4	1.8	0.9	0.7	0.5	0.4	0.2
		10 (8)	7.1	5.0	2.9	1.5	1.2	0.8	0.6	0.4
		25 (4)	8.4	7.4	5.5	3.4	2.8	1.8	1.5	0.9
		50 (0)	8.6	8.1	7.0	5.2	4.5	3.2	2.7	1.8
		70 (00)	8.6	8.2	7.3	5.8	5.2	3.9	3.3	2.3
		120 (250 MCM)	8.7	8.3	7.6	6.5	6.0	4.8	4.2	3.0
400	4	6 (10)	6.6	3.6	1.8	0.9	0.7	0.5	0.4	0.2
		10 (8)	9.2	5.6	3.0	1.5	1.2	0.8	0.6	0.4
		25 (4)	12	9.9	6.5	3.6	2.9	1.9	1.5	1.0
		50 (0)	13	12	9.3	6.1	5.1	3.4	2.8	1.8
		70 (00)	13	12	10	7.2	6.2	4.4	3.6	2.4
		120 (250 MCM)	13	13	11	8.6	7.6	5.7	4.9	3.4
800	6	6 (10)	6.9	3.7	1.9	0.9	0.7	0.5	0.4	0.2
		10 (8)	10	5.8	3.0	1.5	1.2	0.8	0.6	0.4
		25 (4)	15	11	6.9	3.7	3.0	1.9	1.5	1.0
		50 (0)	17	15	11	6.5	5.4	3.5	2.9	1.8
		70 (00)	17	15	12	7.9	6.7	4.6	3.7	2.4
		120 (250 MCM)	17	16	13	9.8	8.6	6.2	5.2	3.5
1,000	6	6 (10)	7.1	3.7	1.9	0.9	0.7	0.5	0.4	0.2
		10 (8)	11	6.0	3.1	1.5	1.2	0.8	0.6	0.4
		25 (4)	18	12	7.1	3.7	3.0	1.9	1.5	1.0
		50 (0)	21	17	12	6.7	5.5	3.6	2.9	1.8
		70 (00)	21	18	13	8.4	7.0	4.7	3.8	2.4
		120 (250 MCM)	22	19	16	11	9.3	6.5	5.4	3.6

## Additional Line Filter Option

If a line input filter option is required for the installation such as a line reactor or a passive harmonic filter, the minimum prospective short-circuit current capability of the source is reduced at the drive connection point and shall be estimated (see Calculation, page 57) with the impedance values given in the table below.

Then, the SCPD type shall be selected according to the drive. If no selection is available, Schneider Electric Customer Care Center (CCC) [www.se.com/CCC](http://www.se.com/CCC) should be contacted.

EMC filter series have no significant effect on the minimum prospective short-circuit current capability of the main source.

Through the line option, the  $I_{sc}$  will be limited to a maximum value independent of the transformer and cable. **Therefore the below equations can be used to estimate the minimum prospective short-circuit current capability.**

$$10 \text{ m}\Omega \leq Xf \leq 400 \text{ m}\Omega \Rightarrow I_{sc_{\max i}} (\text{kA}) = 4.7 - 0.7 \cdot \text{Log}(Xf)$$

$$400 \text{ m}\Omega \leq Xf \leq 2000 \text{ m}\Omega \Rightarrow I_{sc_{\max i}} (\text{kA}) = 2.05 - 0.26 \cdot \text{Log}(Xf)$$

Log: Natural logarithm

### Line Choke Filters Impedance Values

Line Choke Filter	Xf in mΩ
VZ1L004M010, VW3A4551	700
VZ1L007UM50, VW3A4552	300
VZ1L018UM20, VW3A4553	100
VW3A4554	70
VW3A4555	30
VW3A4556	20

## IEC Type Circuit-Breaker — with enclosure

### DANGER

#### HAZARD OF ELECTRIC SHOCK, EXPLOSION, OR FIRE

The opening of the branch-circuit protective device is able to be an indication that a fault current has been interrupted.

- Current-carrying parts and other components of the controller should be examined and replaced if damaged.
- If burnout of the current element of an overload relay occurs, the complete overload relay must be replaced.

**Failure to follow these instructions will result in death or serious injury.**

## Function

The circuit-breaker offers enhanced features versus fuse-link since it cumulates 3 functionalities:

- insulation with lock,
- switch (full load interruption),
- downstream short-circuit protection without replacement.

## Short Circuit Current Ratings: Selection Table

The amp rating of the short circuit protection devices in the table are maximum values **with Enclosure**, in **Heavy Duty**.

#### Note:

- Integral solid state short circuit protection in the drive does not provide branch circuit protection. Branch circuit protection must be provided in accordance with any local codes.
- The drive has a 100 kA interrupt rating on the output of the drive. In addition to providing a rating based on shorting the output of the drive, these short circuit current ratings have been obtained by shorting components internal to the drive. These ratings allow proper coordination of short circuit protection.

**Note:** Verify that the minimum required prospective short-circuit current (Isc) value from the table above is lower than the value estimated in the [Calculation](#) section, page 57.

## 415 Vac Three-phase (50/60 Hz)

**Note:** Suitable for use on a circuit capable of delivering not more than   X   rms symmetrical kiloAmperes, **415 Vac** Volts maximum, when protected by   Z1   with a maximum rating of   Z2  .

Circuit breakers can be chosen as SCPD according to the following table:

Drive Catalog Number	PowerPacT Catalog Number (a) (Z1, Z2)	SCCR (X)		Tesys GV / ComPact Catalog number (Z1, Z2)	I <sub>rm</sub> (A)	SCCR (X)		Minimum Enclosure Volume	
		Min (A)	Max (kA)			Min (A)	Max (kA)	(L)	(in <sup>3</sup> )
ATV340U07N4●	B●L36015	1500	22	GV2L08	51	100	22	53	3223
ATV340U15N4●	B●L36015	1500	22	GV2L10	78	200	22	53	3223
ATV340U22N4●	B●L36015	1500	22	GV2L14	138	300	22	53	3223
ATV340U30N4●	B●L36015	1500	22	GV2L16	170	300	22	53	3223
ATV340U40N4●	B●L36020	1500	22	GV2L16	170	300	22	53	3223
ATV340U55N4●	B●L36025	1500	22	GV2L22	327	600	22	53	3223
ATV340U75N4●	B●L36035	1700	22	GV3L32	448	700	22	53	3223
ATV340D11N4●	B●L36045	1700	22	GV3L40	560	900	22	63	3840
ATV340D15N4●	B●L36060	3000	22	GV3L50	700	1100	22	63	3840
ATV340D18N4●	B●L36070	3000	22	GV3L65	910	1800	22	63	3840
ATV340D22N4●	B●L36090	3000	22	GV3L65	910	1800	22	63	3840
ATV340D30N4E	B●L36125	3500	50	GV4L/LE80	480	1800	50	115	7010
ATV340D37N4E	H●L36150	3500	50	GV4L/LE80	480	1800	50	115	7010
ATV340D45N4E	J●L36175	3500	50	GV4L/LE115	690	2500	50	197	12039
ATV340D55N4E	J●L36200	4000	50	GV4L/LE115	690	2500	50	197	12039
ATV340D75N4E	J●L36250	5000	50	NSX250●M-A220	1980	4700	50	197	12039

**NOTE:** (a): about PowerPacT Catalog Number: for references to be completed, replace ● with the letter corresponding to the breaking performance of the circuit breaker:

**D** for 18 kA, **G** for 35 kA, **J** for 65 kA, **L** for 100 kA, **R** for 100 kA.

# IEC Fuses — with enclosure

## Introduction

⚡⚠ DANGER
<p><b>HAZARD OF ELECTRIC SHOCK, EXPLOSION, OR FIRE</b></p> <p>The opening of the branch-circuit protective device is able to be an indication that a fault current has been interrupted.</p> <ul style="list-style-type: none"> <li>• Current-carrying parts and other components of the controller should be examined and replaced if damaged.</li> <li>• If burnout of the current element of an overload relay occurs, the complete overload relay must be replaced.</li> </ul> <p><b>Failure to follow these instructions will result in death or serious injury.</b></p>

**Note:** Only gR, gS or aR fuses are mandatory in case of using DC bus and/or braking ports, to comply with IEC 61800-5-1 Ed 2.1.

## Short Circuit Current Ratings: Selection Table

The amp rating of the short circuit protection devices in the table are maximum values **with Enclosure**, in **Heavy Duty**.

**Note:**

- Integral solid state short circuit protection in the drive does not provide branch circuit protection. Branch circuit protection must be provided in accordance with any local codes.
- The drive has a 100 kA interrupt rating on the output of the drive. In addition to providing a rating based on shorting the output of the drive, these short circuit current ratings have been obtained by shorting components internal to the drive. These ratings allow proper coordination of short circuit protection.

**Note:** Verify that the minimum required prospective short-circuit current (Isc) value from the table above is lower than the value estimated in the [Calculation](#) section, page 57.

## 415 Vac Three-phase (50/60 Hz)

**Note:** Suitable for use on a circuit capable of delivering not more than   X   rms symmetrical kiloAmperes, **415 Vac** Volts maximum, when protected by   Z1   with a maximum rating of   Z2  .

Current limiting fuses can be chosen as SCPD according to the following table:

Drive Catalog Number	gR-gS-aR (Z1, Z2)		SCCR (X)		Minimum Enclosure Volume	
	(A)	Minimum size	Min (A)	Max (kA)	(L)	(in <sup>3</sup> )
ATV340U07N4●	8	10x38	100	22	53	3223
ATV340U15N4●	12,5	10x38	200	22	53	3223
ATV340U22N4●	16	10x38	200	22	53	3223
ATV340U30N4●	20	10x38	200	22	53	3223
ATV340U40N4●	25	10x38	300	22	53	3223
ATV340U55N4●	40	14x51	500	22	53	3223
ATV340U75N4●	40	14x51	500	22	53	3223
ATV340D11N4●	63	000	1000	22	63	3840
ATV340D15N4●	80	000	1500	22	63	3840
ATV340D18N4●	100	1	1500	22	63	3840
ATV340D22N4●	100	1	1500	22	63	3840
ATV340D30N4E	100	000	1500	50	115	7010
ATV340D37N4E	125	00	2000	50	115	7010
ATV340D45N4E	125	00	2000	50	197	12039
ATV340D55N4E	160	1	2500	50	197	12039
ATV340D75N4E	200	1	4000	50	197	12039

# UL Circuit-Breakers and Fuses

## Reference Document

UL Fuse and circuit-breaker information is provided in the Annex for ATV340 Getting Started (NVE37641).

## Complementary Information

The following table shows the minimum required prospective short-circuit current (Isc) depending on the drive and **associated circuit-breaker**.

Catalog Number	PowerPact Circuit-breakers	Minimum Isc
		(A)
ATV340U07N4•, ATV340U15N4•	H•L36015	1,500
ATV340U22N4•, ATV340U30N4•	H•L36015	1,500
ATV340U40N4•	H•L36020	1,500
ATV340U55N4•	H•L36025	1,500
ATV340U75N4•	H•L36035	1,700
ATV340D11N4•	H•L36045	1,700
ATV340D15N4•	H•L36060	3,000
ATV340D18N4•	H•L36070	3,000
ATV340D22N4•	H•L36090	3,000
ATV340D30N4•	H•L36125	3,500
ATV340D37N4•	H•L36150	3,500
ATV340D45N4•	J•L36175	3,500
ATV340D55N4•	J•L36200	4,000
ATV340D75N4•	J•L36250	5,000

The following table shows the minimum required prospective short-circuit current (Isc) depending on the drive and **associated class J fuse**, according to UL248-8.

Catalog Number	Class J Fuse	Minimum Isc
	to UL248-8 (A)	(A)
ATV340U07N4•	6	300
ATV340U15N4•	12	500
ATV340U22N4•	15	500
ATV340U30N4•	20	500
ATV340U40N4•	25	1,000
ATV340U55N4•, ATV340U75N4•	40	1,500
ATV340D11N4•	60	2,000
ATV340D15N4•	70	2,000
ATV340D30N4•	90	2,500
ATV340D18N4•, ATV340D22N4•, ATV340D37N4•	100	2,500
ATV340D45N4•	150	3,500
ATV340D55N4•, ATV340D75N4•	200	5,000

---

# Drive Mounting

## What's in This Part

Mounting Conditions.....	66
Derating Curves.....	73
Mounting Procedures .....	80

# Mounting Conditions

## Before You Begin

### DANGER

#### HAZARD OF FIRE OR ELECTRIC SHOCK

- The open type product does not provide comprehensive mitigation for fire hazards and protection against direct contact to hazardous live parts.
- Install the product inside a supplementary enclosure which provides appropriate protection against spread of fire and electric shock.

**Failure to follow these instructions will result in death or serious injury.**

### DANGER

#### RISK OF FIRE

The device is suitable for mounting on concrete or other non-combustible surfaces only.

**Failure to follow these instructions will result in death or serious injury.**

Conductive foreign objects may cause parasitic voltage.

### DANGER

#### ELECTRIC SHOCK AND/OR UNANTICIPATED EQUIPMENT OPERATION

- Keep foreign objects such as chips, screws or wire clippings from getting into the product.
- Verify correct seat of seals and cable entries in order to avoid deposits and humidity.

**Failure to follow these instructions will result in death or serious injury.**

The temperature of the products described in this manual may exceed 80 °C (176 °F) during operation.

### WARNING

#### HOT SURFACES

- Ensure that any contact with hot surfaces is avoided.
- Do not allow flammable or heat-sensitive parts in the immediate vicinity of hot surfaces.
- Verify that the product has sufficiently cooled down before handling it.
- Verify that the heat dissipation is sufficient by performing a test run under maximum load conditions.

**Failure to follow these instructions can result in death, serious injury, or equipment damage.**

Power Drive Systems (PDS) can generate strong local electrical and magnetic fields. This can cause interference in electromagnetically sensitive devices.

<b>⚠ WARNING</b>
<p><b>ELECTROMAGNETIC FIELDS</b></p> <ul style="list-style-type: none"> <li>• Keep persons with electronic medical implants, such as pacemakers, away from the equipment.</li> <li>• Do not place electromagnetically sensitive devices in the vicinity of the equipment.</li> </ul> <p><b>Failure to follow these instructions can result in death, serious injury, or equipment damage.</b></p>

## Attach A Label With Safety Instructions

A label kit is provided with the drive.

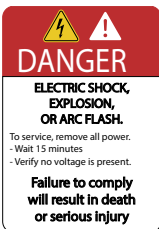
Step	Action
1	Observe the safety regulations in the target country
2	Select the label suitable for the target country
3	<p>Attach the label to the front of the device so that it is clearly visible. Below is the English version. The label can vary depending on the frame size of the product.</p> <div style="border: 1px solid black; padding: 5px; margin: 10px 0;">  <p><b>DANGER</b> ELECTRIC SHOCK, EXPLOSION, OR ARC FLASH.</p> <p>To service, remove all power. - Wait 15 minutes - Verify no voltage is present.</p> <p><b>Failure to comply will result in death or serious injury</b></p> </div> <p><b>NOTE: Products used in Canada</b> according to CSA C22.2 no.274 must comply with the requirement defined by the Canadian Advisory council of Electrical Safety (CACES).</p> <p>It defines that dual language (French and English) safety labeling is required on all products for use in Canada.</p> <p>To fulfill this requirement, add the French language safety label on the front panel of the product.</p>

## Webserver default Password

If the Nameplate is not visible after the drive mounting phase, note or take a photo of the webserver default password, page 25.

# Mounting Types

This table shows the possible mounting types and the resulting IP degree of protection.

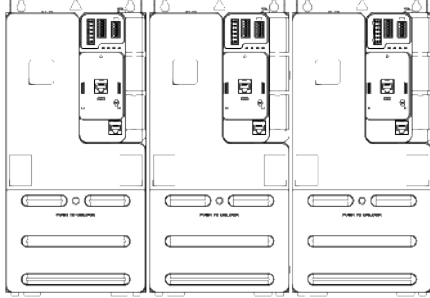
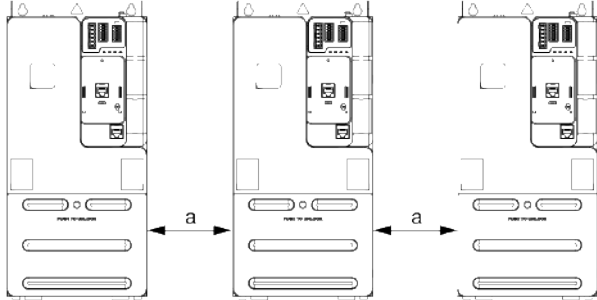
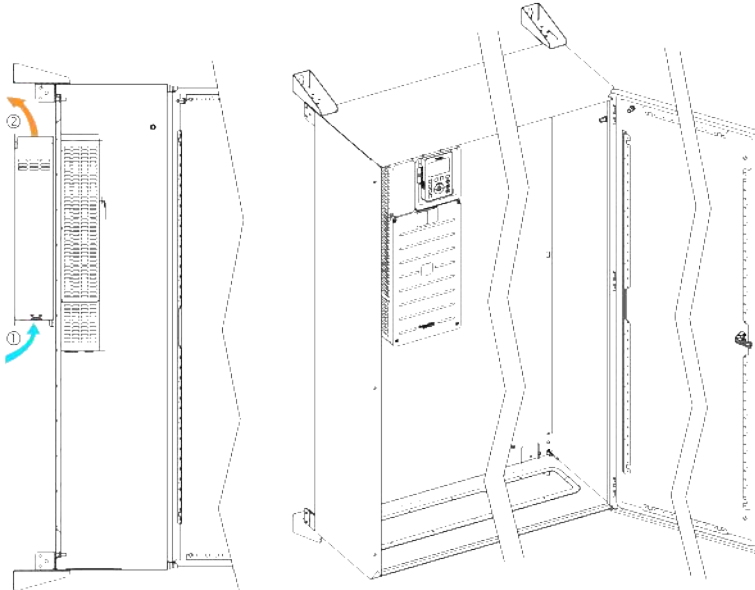
Mounting		Figure
Type	Description	
A	Side by side	 <p>Frame sizes 1, 2 and 3, at ambient temperature <math>\leq 50\text{ }^{\circ}\text{C}</math> (<math>122\text{ }^{\circ}\text{F}</math>)                      Frame sizes 4 and 5: 2 drives only</p>
B	Individual	 <p>Frame sizes 1, 2 and 3: <math>\leq 50\text{ }^{\circ}\text{C}</math> (<math>122\text{ }^{\circ}\text{F}</math>): no restriction for distance a                      Frame sizes 1, 2 and 3: <math>50\text{...}60\text{ }^{\circ}\text{C}</math> (<math>122\text{...}140\text{ }^{\circ}\text{F}</math>): <math>a \geq 50\text{ mm}</math> (2 in)                      Frame sizes 4 and 5: <math>a \geq 110\text{ mm}</math> (4.33 in.)</p>
—	Enclosed with flush-mounting kit for frame sizes 3, 4 and 5	 <p>①: Air inlet, ②: Air outlet</p> <p>This mounting type requires the dedicated mounting kit available on <a href="http://www.se.com">www.se.com</a></p> <p><b>NOTE:</b> Use ProClima software available on <a href="http://www.se.com">www.se.com</a> to support you to integrate Altivar Machine in an enclosure.</p>

# Clearances and Mounting Position in the Cabinet

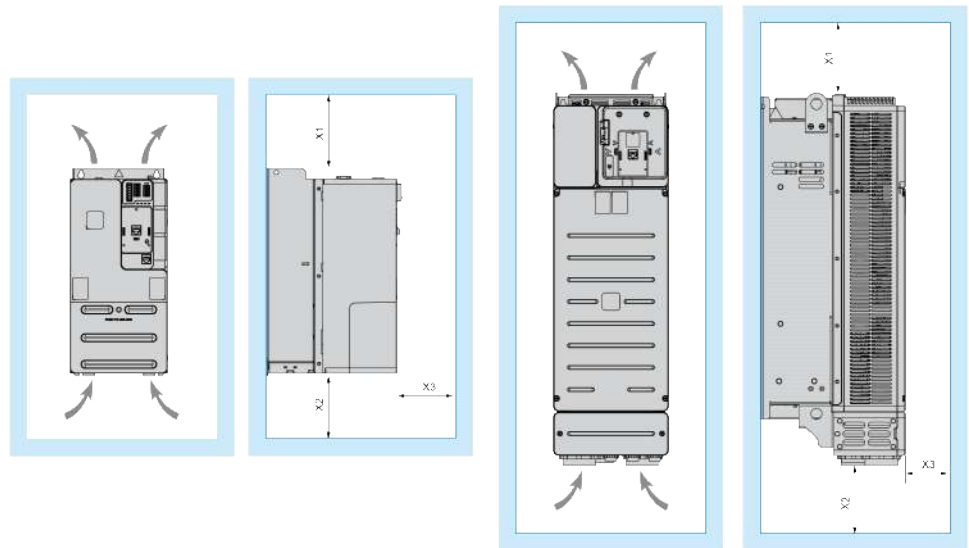

Minimum clearance regarding the drive frame size

Frame Size	X1	X2	X3
1, 2 and 3	≥ 100 mm (3.94 in.) (a)	≥ 100 mm (3.94 in.) (a)	≥ 60 mm (2.36 in.) (b)
4 and 5	≥ 100 mm (3.94 in.)	≥ 100 mm (3.94 in.)	≥ 10 mm (0.39 in.) (c) (d)

(a) Frame sizes 1, 2 and 3 can be fitted with optional EMC kits. These kits could require more free space to cabinet top or bottom

(b) Frame sizes 1, 2 and 3 use front wiring and allow to plug plain text display terminal.

(c) Take into account that the use of the additional module support VW3A3800 requires an increase of **30 mm (1.2 in.)** for slot C.

(d) Take into account that the use of the advanced graphic display terminal, if using the additional module support VW3A3800 together, requires an increase of **50mm (2 in.)**.

## General Mounting Instructions

- Install the drive in a cabinet or in a technical room. No wall mounting installation supported.
- Install drives of frame sizes 1 and 2 on a grounded back plane to improve EMC.
- Mount the drive in a vertical position. This is required for cooling the drive.
- Attach it on the mounting surface in compliance with standards, using the screws with captive washer according to the table given in *Mounting Procedures*, page 80.
- The use of washers is required with all mounting screws.
- Tighten the fixation screws.
- Do not mount the device close to heat sources.
- Avoid environmental effects like high temperatures and high humidity as well as dust, dirt and conductive gases.
- Adhere to the minimum installation distances for required cooling.
- Do not mount the device on flammable materials.
- Install the drive on a solid, vibration-free support.
- Maintain all wiring on backplates or by using existing EMC kits to avoid stress on connectors.
- For frame sizes 1, 2 and 3, use only the connectors supplied with the product for wiring. Connector kits are also available, refer to the *catalog*.

## Power Dissipated in Heavy Duty Mode

**NOTE:** The data is given for rated output current, rated output power and nominal switching frequency. Frame sizes 1...4: 4 kHz, frame size 5: 2.5 kHz.

Catalog Number	Frame Size	Nominal Power		Power Dissipated (1)			Minimum air flow rate required	
				Cooled Area		Total		
		Forced	Natural	W				
		kW	HP		W	W	m <sup>3</sup> /hour	ft <sup>3</sup> /min
ATV340U07N4•	1	0.75	1	49	N/A	49	18	11
ATV340U15N4•	1	1.5	2	69	N/A	69	18	11
ATV340U22N4•	1	2.2	3	90	N/A	90	18	11
ATV340U30N4•	1	3	3	112	N/A	112	19	11
ATV340U40N4•	1	4	5	136	N/A	136	19	11
ATV340U55N4•	2	5.5	7	196	N/A	196	76	45
ATV340U75N4•	2	7.5	10	256	N/A	256	76	45
ATV340D11N4•	3	11	15	313	50	363	128	75
ATV340D15N4•	3	15	20	443	55	498	128	75
ATV340D18N4•	3	18.5	25	559	61	620	128	75
ATV340D22N4•	3	22	30	680	66	746	128	75
ATV340D30N4E•	4	30	40	661	113	774	240	141
ATV340D37N4E•	4	37	50	780	123	903	240	141
ATV340D45N4E•	5	45	60	776	143	919	295	174
ATV340D55N4E•	5	55	75	987	156	1143	295	174
ATV340D75N4E•	5	75	100	1364	185	1549	295	174

(1) The total losses are the sum of the losses in Forced cooled area, and the Natural cooled area (see below). When using the Push through/Flush mounting kit for frame size 3, 4 and 5 the losses of the forced cooled area are outside the cabinet.

## Power Dissipated in Normal Duty Mode

**NOTE:** The data is given for rated output current, rated output power and nominal switching frequency. Frame sizes 1...4: 4 kHz, frame size 5: 2.5 kHz.

Catalog Number	Frame Size	Nominal Power		Power Dissipated (1)			Minimum air flow rate required	
				Cooled Area		Total		
		Forced	Natural	W				
		kW	HP		W	W	m <sup>3</sup> /hour	ft <sup>3</sup> /min
ATV340U07N4•	1	1.1	1.5	61	N/A	61	18	11
ATV340U15N4•	1	2.2	3	94	N/A	94	18	11
ATV340U22N4•	1	3	3	122	N/A	122	18	11
ATV340U30N4•	1	4	5	141	N/A	141	19	11
ATV340U40N4•	1	5.5	7	200	N/A	200	19	11
ATV340U55N4•	2	7.5	10	256	N/A	256	76	45
ATV340U75N4•	2	11	15	369	N/A	369	76	45
ATV340D11N4•	3	15	20	430	55	485	128	75
ATV340D15N4•	3	18.5	25	563	61	624	128	75
ATV340D18N4•	3	22	30	585	66	651	128	75
ATV340D22N4•	3	30	40	820	78	898	128	75
ATV340D30N4E•	4	37	50	802	122	924	240	141
ATV340D37N4E•	4	45	60	949	132	1081	240	141
ATV340D45N4E•	5	55	75	933	155	1088	295	174
ATV340D55N4E•	5	75	100	1389	185	1574	295	174
ATV340D75N4E•	5	90	125	1899	205	2104	295	174

(1) The total losses are the sum of the losses in Forced cooled area, and the Natural cooled area (see below). When using the Push through/Flush mounting kit for frame size 3, 4 and 5 the losses of the forced cooled area are outside the cabinet.

## Constant Losses

**NOTE:** If an interface is not used, the associated losses must not be considered.

Device	Connector	Losses in W
Display terminal	HMI	1.5
Analog I/Os	CN6	1.5
Onboard Encoder	CN3	0.5
Module Slot A/GP-FB	-	3
Module Slot B/GP-ENC	-	3
Module Slot C/GP-SF / Advanced Ethernet / Sercos III	- / Eth1, 2 / S3P1, S3P2	1
Digital inputs	CN6	1
200 mA output	CN2	4.8
<b>Sum:</b>		<b>16.3</b>

# Derating Curves

## Description

Derating curves for the nominal drive current ( $I_n$ ) as a function of temperature and switching frequency. Refer to the Mounting Conditions chapter, page 66 for the mounting types description.

### Frame Size 1 - 0.7 kW

No derating required.

**NOTE:** For 60°C operation:

- Type B mounting required
- No plain text display terminal plugged

### Frame Size 1 - 1.5 kW

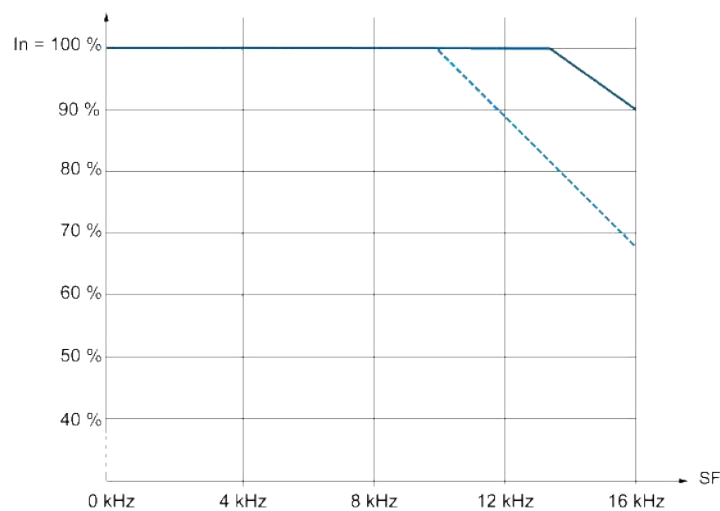

— 40 °C (104 °F) - Mounting type A

- - - 50 °C (122 °F) - Mounting type A

In Normal duty, these curves are also valid for a temperature 10°C less than the given temperatures.

**NOTE:** For 60°C operation:

- Type B mounting required
- No plain text display terminal plugged
- No current derating needed

## Frame Size 1 - 2.2 kW

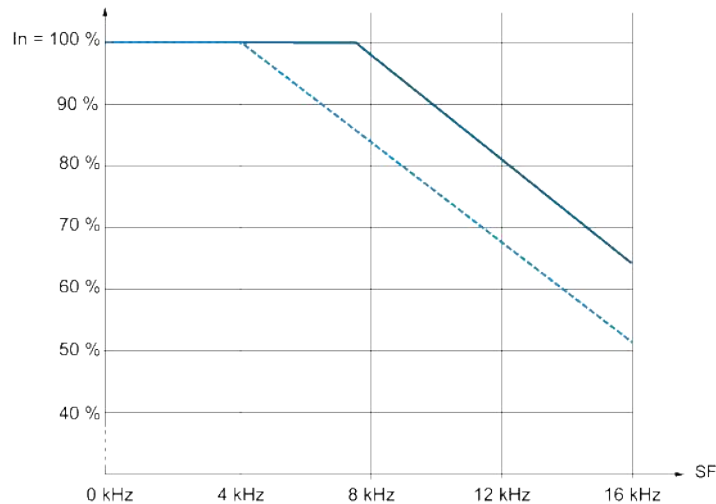

— 40 °C (104 °F) - Mounting type A

- - - 50 °C (122 °F) - Mounting type A

In Normal duty, these curves are also valid for a temperature 10°C less than the given temperatures.

**NOTE:** For 60°C operation:

- Type B mounting required
- No plain text display terminal plugged
- No current derating needed

## Frame Size 1 - 3 kW

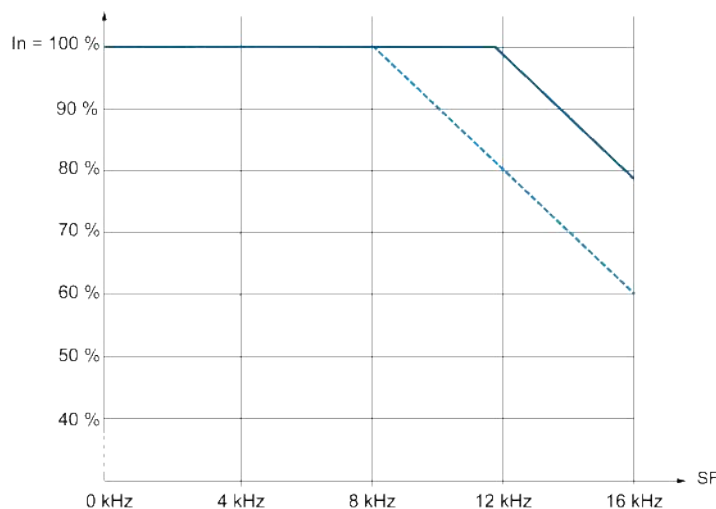

— 40 °C (104 °F) - Mounting type A

- - - 50 °C (122 °F) - Mounting type A

In Normal duty, these curves are also valid for a temperature 10°C less than the given temperatures.

**NOTE:** For 60°C operation:

- Type B mounting required
- No plain text display terminal plugged
- No current derating needed

## Frame Size 1 - 4 kW

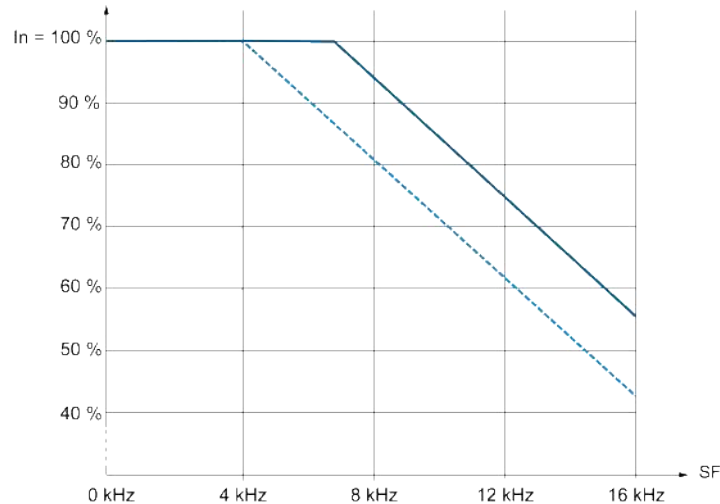

— 40 °C (104 °F) - Mounting type A

- - - 50 °C (122 °F) - Mounting type A

In Normal duty, these curves are also valid for a temperature 10°C less than the given temperatures.

**NOTE:** For 60°C operation:

- Type B mounting required
- No plain text display terminal plugged
- No current derating needed

## Frame Size 2 - 5.5 kW

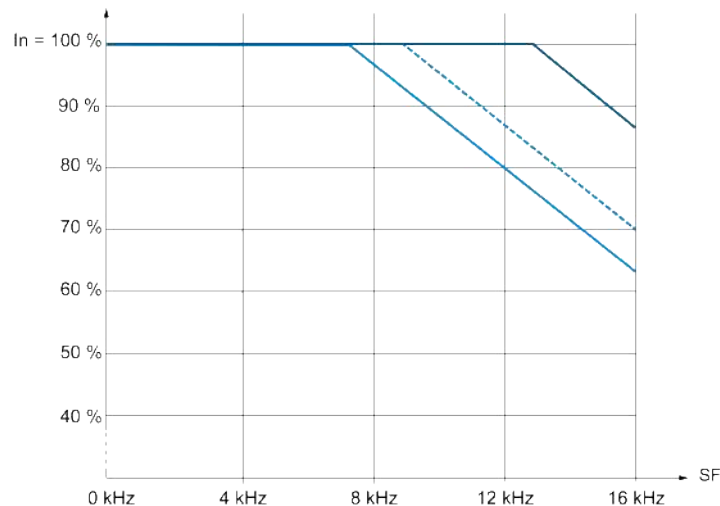

— 40 °C (104 °F) - Mounting type A and B

- - - 50 °C (122 °F) - Mounting type A and B

— 60 °C (140 °F) - Mounting type B

In Normal duty, these curves are also valid for a temperature 10°C less than the given temperatures.

**NOTE:** For 60°C operation:

- No side-by-side mounting
- No plain text display terminal plugged

## Frame Size 2 - 7.5 kW

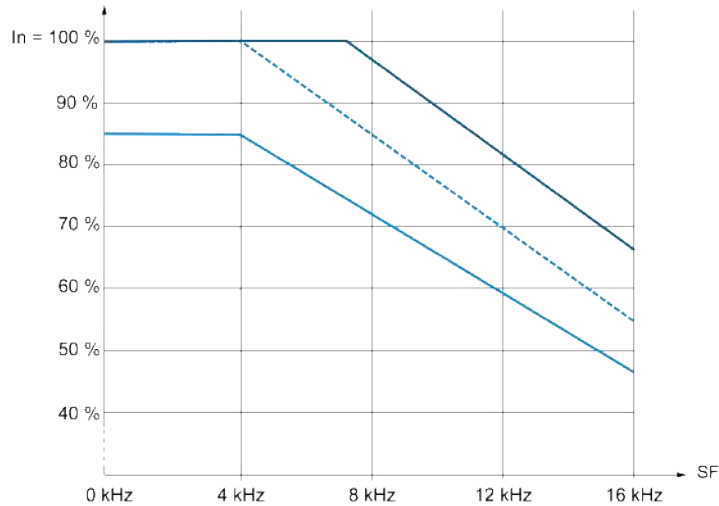

- 40 °C (104 °F) - Mounting type A and B
- - - 50 °C (122 °F) - Mounting type A and B
- 60 °C (140 °F) - Mounting type B

In Normal duty, these curves are also valid for a temperature 10°C less than the given temperatures.

**NOTE:** For 60°C operation:

- No side-by-side mounting
- No plain text display terminal plugged

## Frame Size 3 - 11 kW

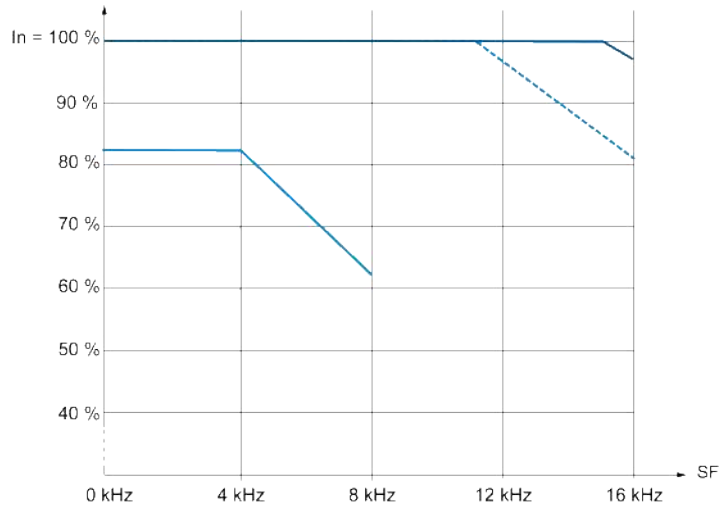

- 40 °C (104 °F) - Mounting type A and B
- - - 50 °C (122 °F) - Mounting type B
- 60 °C (140 °F) - Mounting type B

In Normal duty, these curves are also valid for a temperature 10°C less than the given temperatures.

**NOTE:**

- For operation > 40°C: No side-by-side mounting
- For operation > 50°C: No plain text display terminal plugged

## Frame Size 3 - 15 kW

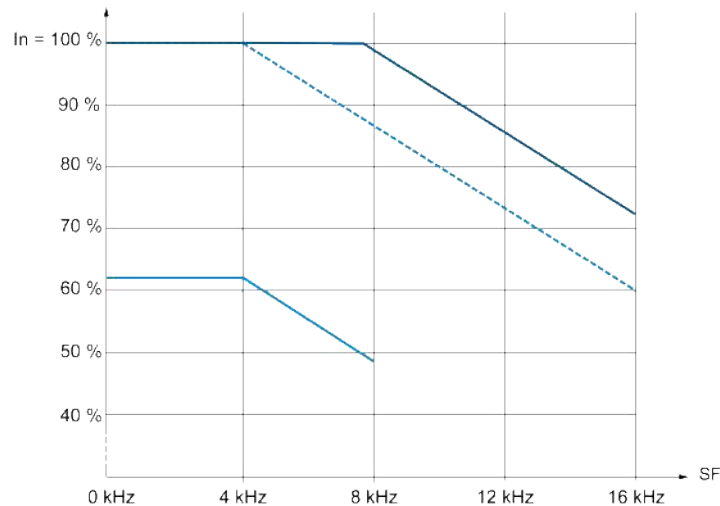

— 40 °C (104 °F) - Mounting type A and B

- - - 50 °C (122 °F) - Mounting type B

— 60 °C (140 °F) - Mounting type B

In Normal duty, these curves are also valid for a temperature 10°C less than the given temperatures.

**NOTE:**

- For operation > 40°C: No side-by-side mounting
- For operation > 50°C: No plain text display terminal plugged

## Frame Size 3 - 18.5 kW

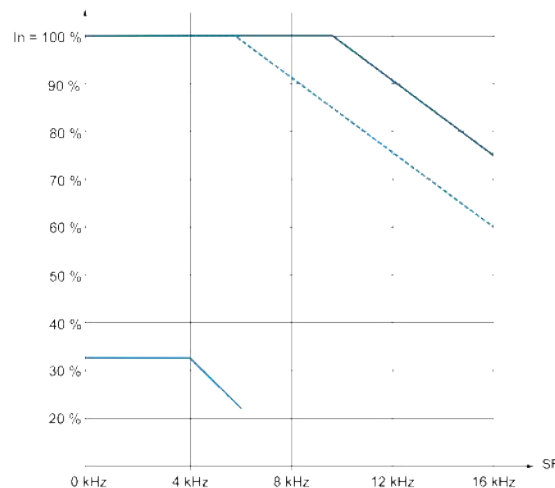

— 40 °C (104 °F) - Mounting type A and B

- - - 50 °C (122 °F) - Mounting type B

— 60 °C (140 °F) - Mounting type B

In Normal duty, these curves are also valid for a temperature 10°C less than the given temperatures.

**NOTE:**

- For operation > 40°C: No side-by-side mounting
- For operation > 50°C: No plain text display terminal plugged

## Frame Size 3 - 22 kW

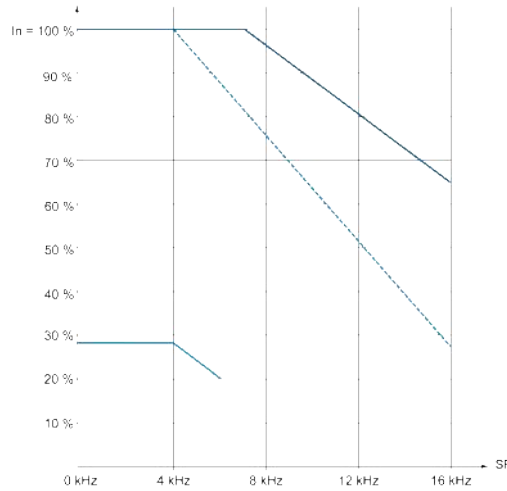

———— 40 °C (104 °F) - Mounting type A and B

..... 50 °C (122 °F) - Mounting type B

———— 60 °C (140 °F) - Mounting type B

In Normal duty, these curves are also valid for a temperature 10°C less than the given temperatures.

**NOTE:**

- For operation > 40°C: No side-by-side mounting
- For operation > 50°C: No plain text display terminal plugged

## Frame Size 4 - 30 and 37 kW

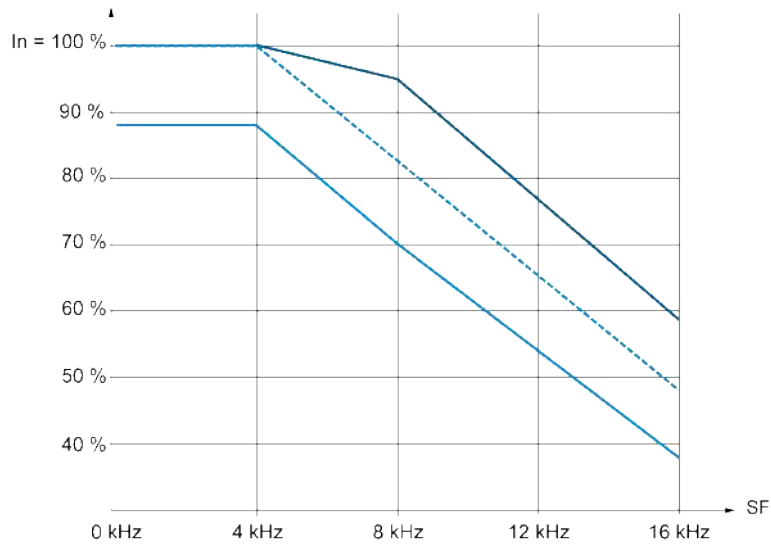

———— 40 °C (104 °F) - Mounting type A and B

..... 50 °C (122 °F) - Mounting type A and B

———— 60 °C (140 °F) - Mounting type B

## Frame Size 5 - 45, 55 and 75 kW

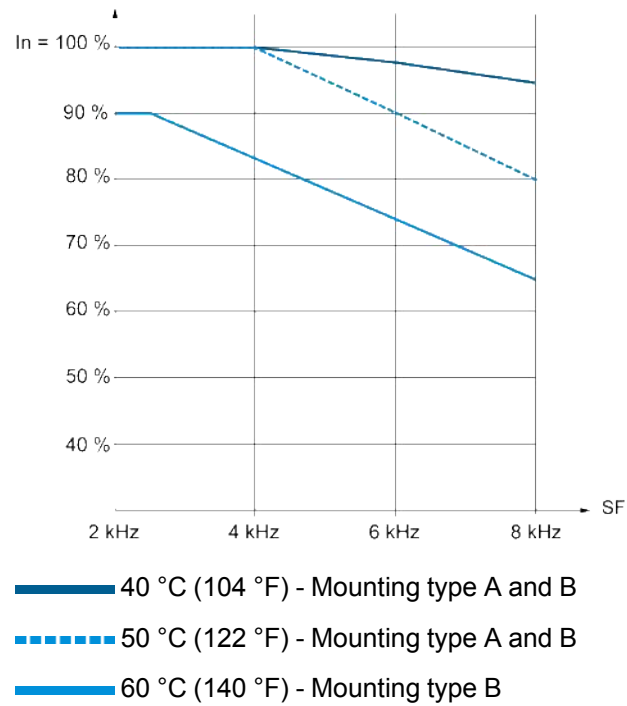

# Mounting Procedures

## Mounting Screws

Frame Size	Screw diameter
1	5 mm (0.2 in)
2	5 mm (0.2 in)
3	5 mm (0.2 in)
4	6 mm (0.24 in)
5	8 mm (0.3 in)

**NOTE:**

- Fixation by screws is required for all drives ratings.
- Screws are not delivered with the product.

## Mounting Procedure For Frame Sizes 1 to 3

Mounting the drive does not require preliminary dismantling operation. Simply mount the drive to its support using the 4 screws with captive washer, according to the table above.

Mount the drive on a metallic backplane for EMC requirements.

## Mounting Procedure For Frame Sizes 4 and 5

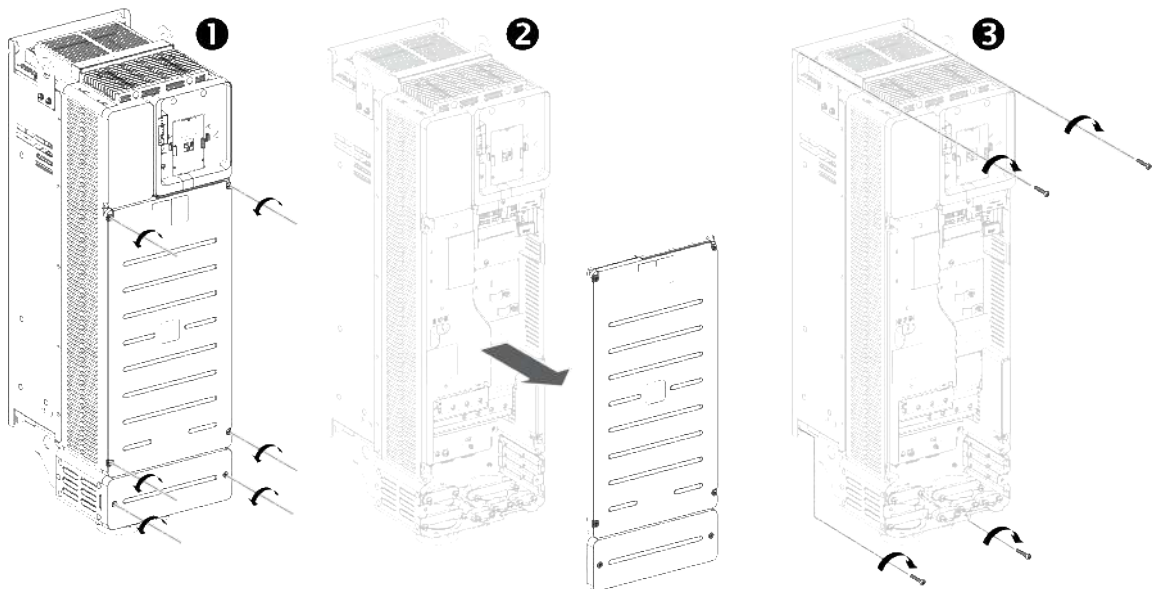

Perform the following instructions

Step	Action
1	Unscrew the 6 screws (frame size 4) or the 8 screws (frame size 5) attaching the front and bottom covers
2	Remove the covers
3	Attach the drive on the mounting surface using the screws with captive washer, according to the table above, page 80.

# Drive wiring

## What's in This Part

General Wiring Information .....	82
General Wiring Diagrams.....	95
Built-in EMC Filter .....	104
Power Part.....	110
Control Part .....	124
SK EXT SRC Switch Configuration .....	157
PTO - DQ Switch (SW2) Configuration.....	161
Safe Torque Off STO Function.....	166
Digital Inputs Wiring.....	168
Digital Outputs Wiring .....	174
Relay Contacts Wiring .....	177

# General Wiring Information

## What's in This Chapter

Wiring Instructions.....	83
Cable Length Instructions For Power Part .....	88
Cable Length Instructions For the Control Part.....	90
Electromagnetic Compatibility .....	92

# Wiring Instructions

## General Instructions

The entire installation procedure must be performed without voltage present.

<b>⚡⚠ DANGER</b>
<b>HAZARD OF ELECTRIC SHOCK, EXPLOSION OR ARC FLASH</b>
Read and understand the instructions in <b>Product Related Information</b> chapter before performing any procedure in this chapter.
<b>Failure to follow these instructions will result in death or serious injury.</b>

<b>⚡⚠ DANGER</b>
<b>HAZARD OF ELECTRIC SHOCK, EXPLOSION, OR ARC FLASH</b>
Before applying voltage to and configuring the product, verify that it is properly wired.
<b>Failure to follow these instructions will result in death or serious injury.</b>

The product has a leakage current greater than 3.5 mA. If the protective ground connection is interrupted, a hazardous touch current may flow if the product is touched.

<b>⚡⚠ DANGER</b>
<b>ELECTRIC SHOCK CAUSED BY HIGH LEAKAGE CURRENT</b>
Verify compliance with all local and national electrical code requirements as well as all other applicable regulations with respect to grounding of the entire drive system installation.
<b>Failure to follow these instructions will result in death or serious injury.</b>

Product may perform unexpected movements because of incorrect wiring, incorrect settings, incorrect data or other errors.

<b>⚠ WARNING</b>
<b>UNANTICIPATED EQUIPMENT OPERATION</b>
<ul style="list-style-type: none"> <li>• Carefully install the wiring in accordance with the EMC requirements.</li> <li>• Do not operate the product with unknown or unsuitable settings or data.</li> <li>• Perform a comprehensive commissioning test.</li> </ul>
<b>Failure to follow these instructions can result in death, serious injury, or equipment damage.</b>

## Residual Current Device

Direct current can be introduced in the protective ground conductor of this device. If a residual current device (RCD / GFCI) or a residual current monitor (RCM) is used for additional protection against direct or indirect contact, the following specific types must be used:

### **⚠ WARNING**

#### **DIRECT CURRENT CAN BE INTRODUCED INTO THE PROTECTIVE GROUND CONDUCTOR**

- Use a Type A or Type F Residual Current Device (RCD / GFCI) or a Residual Current Monitor (RCM) for single-phase devices connected to a phase and to the neutral conductor.
- Use a Type B Residual Current Device (RCD / GFCI) or a Residual Current Monitor (RCM) that has approval for use with frequency inverters and is sensitive to all types of current for three-phase devices and for single-phase devices not connected to a phase and the neutral conductor.

**Failure to follow these instructions can result in death, serious injury, or equipment damage.**

Further conditions for use of a residual current device:

- The device has an increased leakage current at the moment power is applied. Use a residual current device (RCD / GFCI) or a residual current monitor (RCM) with a response delay.
- High-frequency currents must be filtered.

Choose a suitable model integrating:

- High frequency current filtering
- A time delay that helps to prevent a triggering of the upstream device caused by the load from stray capacitance on power-on. The time delay is not available for 30 mA device; in this case, choose devices with immunity against nuisance triggering.

Due to high leakage current in standard operation, we recommend choosing at least a 300 mA device.

If the installation requires a residual current device less than 300 mA, it can be possible to use a device lower than 300 mA by changing the IT switch position (drive sizes 1...3) or by removing the screws (drive sizes 4 and 5) according to the instructions given in the [Operation on an IT System](#), page 105.

If the installation includes several drives, provide one residual current device per drive.

## Equipment Grounding

### **⚠️⚠️ DANGER**

#### **ELECTRIC SHOCK CAUSED BY INSUFFICIENT GROUNDING**

- Verify compliance with all local and national electrical code requirements as well as all other applicable regulations with respect to grounding of the entire device.
- Ground the device before applying voltage.
- The cross section of the protective ground conductor must comply with the applicable standards.
- Do not use conduits as protective ground conductors; use a protective ground conductor inside the conduit.
- Do not consider cable shields to be protective ground conductors.

**Failure to follow these instructions will result in death or serious injury.**

Tighten the grounding screws according to the instructions given in the *Ground Connection Cables*, page 111.

## Control Cable Instructions

#### **NOTE:**

- Analog inputs and outputs AIx, AQx, COM use shielded cable and each analog input and output has its own COM line.
- Each PTC input has its own COM line, not shared with other Inputs/Outputs.
- All digital inputs DIx use one common 24V line in source mode or one common COM line in sink mode. This 24V or COM line is used only for DIx.
- Digital outputs:
  - Frame sizes 1...3: DQCOM line must not be shared with other 24V or COM lines.
  - Frame sizes 4 and 5: DQ+/DQ- uses a 24V or a COM line which is not shared with other Inputs/Outputs.
- Safe torque off inputs  $\overline{\text{STOA}}$  / STOB use shielded cables and one common 24V line. This 24V line is used only for STOA / STOB.

**NOTE:** For cable lengths, refer to the table given in the *Cable Length Instructions For Power Part*, page 88.

## Before Wiring The Frame Sizes 1...3

The packaging of these drives includes covers to be cut off and placed over the top side of the drive before wiring operations. These covers help to avoid foreign conductive parts or liquids to fall into the drive.

The example shown below is for frame size 3

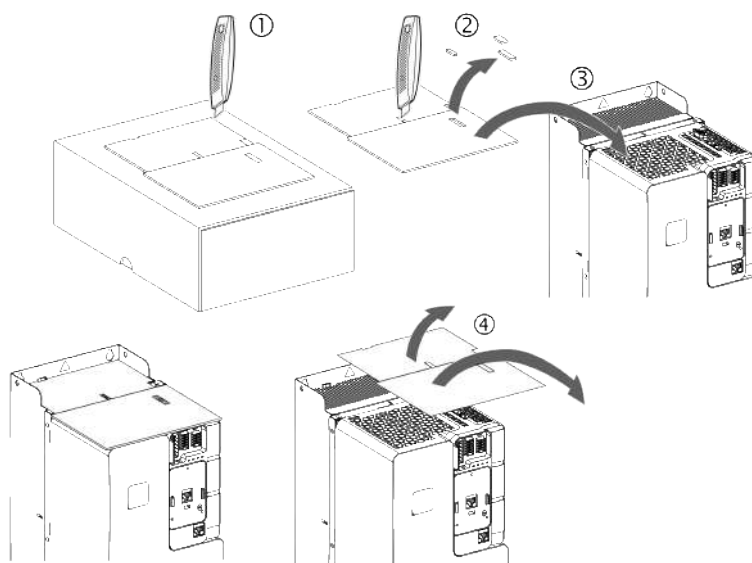

Perform the following instructions to mount the covers

Step	Action
1	Cut the covers from the packaging
2	Cut and discard the cutouts
3	Fit the covers on the drive
4	Install the drive
5	Remove top covers for normal operation

## Cable Characteristics

Only use cables with insulator heat resistance of 75°C (167°F) min.

If you are using cables longer than 150 m (492 ft) between the drive and the motor, add output filters (for more details refer to the [catalog](#)).

Use a shielded cable to meet the requirements of Category C2 or C3 according to the standard IEC 61800-3, except when using a sinus filter. In this case, the use of a non-shielded motor cable is possible.

To limit the currents in common mode, use common mode output filters (ferrite) in order to reduce the circulating currents in the motor windings.

Standard linear capacity cables can be used. Use of cables with lower linear capacity could increase cable length performances.

The overvoltage limitation function **[Motor surge limit.] 5 V L** enables you to increase the cable length while decreasing the torque performances. Refer to the [Programming manual](#).

## Power Part Cables Stripping lengths

Catalog Number and Frame Size [•]		Cable Stripping Length	
		Input	Output
		mm (in.)	mm (in.)
ATV340U07N4•...U40N4•	[1]	8 ± 1 (0.32 ± 0.04)	8 ± 1 (0.32 ± 0.04)
ATV340U55N4•...U75N4	[2]	9 ± 1 (0.35 ± 0.04)	9 ± 1 (0.35 ± 0.04)
ATV340D11N4•...D22N4•	[3]	18 ± 2 (0.71 ± 0.08)	18 ± 2 (0.71 ± 0.08)
ATV340D30N4E•, D37N4E•	[4]	26 ± 2 (1.02 ± 0.08)	26 ± 2 (1.02 ± 0.08)
ATV340D45N4E•...D75N4E•	[5]	32 ± 3 (1.26 ± 0.12)	32 ± 3 (1.26 ± 0.12)

## Control Part Cables Stripping lengths for Frame Size 1...3

IO terminal	Cable Stripping Length in mm (in.)
STOA, STOB, 24V, 0V	11.5 ± 0.5 (0.45 ± 0.02)
R1A, R1B, R1C, R2A, R2C	9.5 ± 0.5 (0.37 ± 0.02)
DQCOM, DQ1, DQ2, DISUP, SHLD, DI1, DI2, DI3, DI4, DI5, AQ1, AI1, +AI2, -AI2, COM, 10V	7.5 ± 0.5 (0.29 ± 0.02)

## Control Part Cables Stripping lengths for Frame Size 4 and 5

IO terminal	Cable Stripping Length in mm (in.)
R1A, R2B, R1C, R2A, R2C, R3A, R3C	11 (0.43)
STOA, STOB, 24V, 10V, AI1, COM, AI2, AI3, AQ1, AQ2, COM DQ-	7.5 ± 0.5 (0.29 ± 0.02)
P24, 0V, DI1, DI2, DI3, DI4, DI5, DI6, DI7, DI8, 24V DQ+	6.5 ± 0.5 (0.25 ± 0.02)

# Cable Length Instructions For Power Part

## Long Cable Lengths Consequences

**NOTE:** Maximum cable length is 100 m (328 ft).

When drives are used with motors, a combination of fast switching transistors and long motor cables can even cause peak voltages up to twice the DC link voltage. This high peak voltage can cause premature aging of motor winding insulation which leads to motor breakdown.

The overvoltage limitation function will enable to increase the cable length while decreasing the torque performances.

## Length Of Motor Cables

Because of the permitted mains disturbances, the allowed overvoltages at the motor, the occurring bearing currents and the permitted heat losses the distance between inverter and motor(s) is limited.

The maximum distance heavily depends on the used motors (insulation material), the type of motor cable used (shielded/unshielded), as well as the cable laying (cable channel, underground installation...).

## Dynamic Voltage Load Of The Motor

Overvoltages at the motor terminals result from reflection in the motor cable. Basically the motors are stressed with measurable higher voltage peaks from a motor cable length of 10 m. With the length of the motor cable also the value of overvoltage increases.

The steep edges of the switching impulses at the output side of the frequency inverter lead to a further load of the motors. The slew rate of the voltage is typically over 5 kV/μs but it decreases with the length of the motor cable

Use a shielded cable to meet the requirements of Category C2 or C3 according to the standard IEC 61800-3.

Standard linear capacity cables can be used with Altivar Machine. Use of cables with lower linear capacity could increase cable length performances.

To reduce the voltage stress on the motor windings an overvoltage limitation function [**Motor surge limit.**]  $5 \propto L$  can be activated when using long motor cables, within the maximum cable length of 100 m (328 ft), while decreasing the torque performances. Refer to the programming manual.

## Corrective Actions Overview

A number of simple measures can be taken to help enhance the motor life time:

- Specification of a motor designed for speed drive applications (IEC60034-25 B or NEMA 400 should be prescribed).
- Reduce to a minimum the distance between motor and drive.
- Use unshielded cables.

**NOTE:** EMC performance not guaranteed with unshielded cables

- Reduce the drive switching frequency (a reduction to 2.5 kHz is recommended.)

## Additional Information

Further detailed technical information is available in the following white paper *An Improved Approach for Connecting VSD and Electric Motors* available on [www.se.com](http://www.se.com).

# Cable Length Instructions For the Control Part

## Control Cable Lengths For Frame Sizes 1...3

Control terminal Input/Output Cables		Maximum wires length depending on cable cross section (*)	
		1.5 mm <sup>2</sup> / AWG16	0.5 mm <sup>2</sup> / AWG20
Analog inputs AI1, AI3	voltage: 0 - 10 V	30 m / 98 ft	30 m / 98 ft
	current: 0 - 20 mA	3000 m / 9840 ft	1000 m / 3280 ft
	PT100	30 m / 98 ft	10 m / 32 ft
	PT1000	300 m / 984 ft	100 m / 328 ft
	KTY84	300 m / 984 ft	100 m / 328 ft
	PTC	300 m / 984 ft	100 m / 328 ft
Differential analog input +AI2 / -AI2	voltage: -10 V / + 10 V	30 m / 98 ft	30 m / 98 ft
Output supply 10V		30 m / 98 ft	30 m / 98 ft
Analog output AQ1	voltage: 0 - 10 V	30 m / 98 ft	10 m / 32 ft
	current: 0 - 20 mA	3000 m / 9840 ft	1000 m / 3280 ft
Output power supply 24V	200 mA max.	300 m / 984 ft	100 m / 328 ft
Digital inputs DI1...DI5, DQ1, DQ2		3000 m / 9840 ft	1000 m / 3280 ft
Safe Torque Off inputs STOA, STOB		3000 m / 9840 ft	1000 m / 3280 ft
Digital output DQ1, DQ2 / DQCOM	100 mA max.	400 m / 1310 ft	130 m / 426 ft
Control power supply input P24	24 V input	120 m / 390 ft	40 m / 130 ft
(*) Shorter cable lengths or smaller cable cross sections can be adjusted using linear interpolation with the values listed in the table. For example: maximum 10 m / 32 ft with 0.5 mm <sup>2</sup> / AWG20 and maximum 30 m with 1.5 mm <sup>2</sup> / AWG16 listed in the table, is equivalent to maximum 20 m / 65 ft with 1 mm <sup>2</sup> / AWG17.			

## Control Cable Lengths For Frame Sizes 4 and 5

**NOTE:**

- Analog inputs and outputs AIx, AQx, COM use shielded cable and each analog input and output has its own COM line.
- Each PTC input has its own COM line, not shared with other Inputs/Outputs.
- All digital inputs DIx use one common 24V line in source mode or one common COM line in sink mode. This 24V or COM line is used only for DIx.
- Digital output DQ+/DQ- uses a 24V or a COM line which is not shared with other Inputs/Outputs.
- Safe torque off inputs STOA / STOB use shielded cables and one common 24V line. This 24V line is used only for STOA / STOB.

Control terminal Input/Output Cables		Maximum wires length depending on cable cross section	
		1.5 mm <sup>2</sup> / AWG16	0.5 mm <sup>2</sup> / AWG20
Analog inputs AI1, AI3	voltage: 0 - 10 V	30 m / 98 ft	30 m / 98 ft
	current: 0 - 20 mA	3000 m / 9840 ft	1000 m / 3280 ft
	PT100	30 m / 98 ft	10 m / 32 ft
	PT1000	300 m / 984 ft	100 m / 328 ft
	KTY84	300 m / 984 ft	100 m / 328 ft
	PTC	300 m / 984 ft	100 m / 328 ft
Analog input AI2	voltage: 0 - 10 V	30 m / 98 ft	30 m / 98 ft
Output supply 10V		30 m / 98 ft	30 m / 98 ft
Analog outputs AQ1, AQ2	voltage: 0 - 10 V	30 m / 98 ft	10 m / 32 ft
	current: 0 - 20 mA	3000 m / 9840 ft	1000 m / 3280 ft
Output power supply 24V	200 mA max.	300 m / 984 ft	100 m / 328 ft
Digital inputs DI1...DI8		3000 m / 9840 ft	1000 m / 3280 ft
Safe Torque Off inputs STOA, STOB		3000 m / 9840 ft	1000 m / 3280 ft
Digital output DQ+, DQ-	100 mA max.	600 m / 1968 ft	200 m / 656 ft
Control power supply input P24	24 V input	120 m / 390 ft	40 m / 130 ft
(*) Shorter cable lengths or smaller cable cross sections can be adjusted using linear interpolation with the values listed in the table. For example: maximum 10 m / 32 ft with 0.5 mm <sup>2</sup> / AWG20 and maximum 30 m with 1.5 mm <sup>2</sup> / AWG16 listed in the table, is equivalent to maximum 20 m / 65 ft with 1 mm <sup>2</sup> / AWG17.			

## Electromagnetic Compatibility

Signal interference can cause unexpected responses of the device and of other equipment in the vicinity of the device.

### ⚠ WARNING

#### SIGNAL AND EQUIPMENT INTERFERENCE

- Install the wiring in accordance with the EMC requirements described in this document.
- Verify compliance with the EMC requirements described in this document.
- Verify compliance with all EMC regulations and requirements applicable in the country in which the product is to be operated and with all EMC regulations and requirements applicable at the installation site.

**Failure to follow these instructions can result in death, serious injury, or equipment damage.**

## Limit Values

This product meets the EMC requirements according to the standard IEC 61800-3 if the measures described in this manual are implemented during installation.

If the selected composition (product itself, mains filter, other accessories and measures) does not meet the requirements of category C1, the following information applies as it appears in IEC 61800-3:

### ⚠ WARNING

#### RADIO INTERFERENCE

In a domestic environment this product may cause radio interference in which case supplementary mitigation measures may be required.

**Failure to follow these instructions can result in death, serious injury, or equipment damage.**

## EMC requirements for the control cabinet

EMC measures	Objective
Use mounting plates with good electrical conductivity, connect large surface areas of metal parts, remove paint from contact areas.	Good conductivity due to large surface contact.
Ground the control cabinet, the control cabinet door and the mounting plate with ground straps or ground wires. The conductor cross section must be at least 10 mm <sup>2</sup> (AWG 8). Install frame size 1 and 2 drives on grounded metal back plane.	Reduces emissions.
Fit switching devices such as power contactors, relays or solenoid valves with interference suppression units or arc suppressors (for example, diodes, varistors, RC circuits).	Reduces mutual interference.
Install power components and control components separately.	

## Shielded cables

EMC measures	Objective
Connect large surface areas of cable shields, use cable clamps and ground straps.	Reduces emissions.
Use cable clamps to connect a large surface area of the shields of all shielded cables to the mounting plate at the control cabinet entry.	
Ground shields of digital signal wires, page 95 at both ends by connecting them to a large surface area or via conductive connector housings	Reduces interference affecting the signal wires, reduces emissions
Ground the shields of analog signal wires directly at the device (signal input); insulate the shield at the other cable end or ground it via a capacitor (for example, 10 nF, 100 V or higher).	Reduces ground loops due to low-frequency interference.
Use only shielded motor cables with copper braid and a coverage of at least 85%, ground a large surface area of the shield at both ends.	Diverts interference currents in a controlled way, reduces emissions.

## Cable Installation

EMC measures	Objective
Do not route fieldbus cables and signal wires in a single cable duct together with lines with DC and AC voltages of more than 60 V. (Fieldbus cables, signal lines and analog lines may be in the same cable duct)  Recommendation: Use separate cable ducts at least 20 cm apart.	Reduces mutual interference.
Keep cables as short as possible. Do not install unnecessary cable loops, use short cables from the central grounding point in the control cabinet to the external ground connection.	Reduces capacitive and inductive interference.
Use equipotential bonding conductors in the following cases: wide-area installations, different voltage supplies and installation across several buildings.	Reduces current in the cable shield, reduces emissions.
Use fine stranded equipotential bonding conductors.	Diverts high-frequency interference currents
If motor and machine are not conductively connected, for example by an insulated flange or a connection without surface contact, you must ground the motor with a ground strap or a ground wire. The conductor cross section must be at least 10 mm <sup>2</sup> (AWG 6).	Reduces emissions, increases immunity.
Use twisted pair for the DC supply.  For digital and analog inputs use shielded twisted cables with a pitch of between 25...50 mm (1...2 in).	Reduces interference affecting the signal cables, reduces emissions.

## Power Supply

EMC measures	Objective
Operate product on mains with grounded neutral point.	Enables effectiveness of mains filter.
Surge arrester if there is a risk of overvoltage.	Reduces the risk of damage caused by overvoltage.

## Additional measures for EMC improvement

Depending on the application, the following measures can improve the EMC-dependent values:

EMC measures	Objective
Use mains chokes	Reduces mains harmonics, prolongs product service life.
Use external mains filters	Improves the EMC limit values.
Additional EMC measures, for example mounting in a closed control cabinet with 15 dB shielding attenuation of radiated interference	

**NOTE:** If using an additional input filter, it should be mounted side by side to the drive and connected directly to the supply mains via an unshielded cable.

# General Wiring Diagrams

## What's in This Chapter

Wiring Diagrams for Frame Sizes 1...3: ATV340U07N4•...D22N4•.....	96
Wiring Diagrams for Frame Sizes 4 and 5: ATV340D30N4E...D75N4E .....	100

# Wiring Diagrams for Frame Sizes 1...3: ATV340U07N4•... D22N4•

## Control Block Wiring Diagram

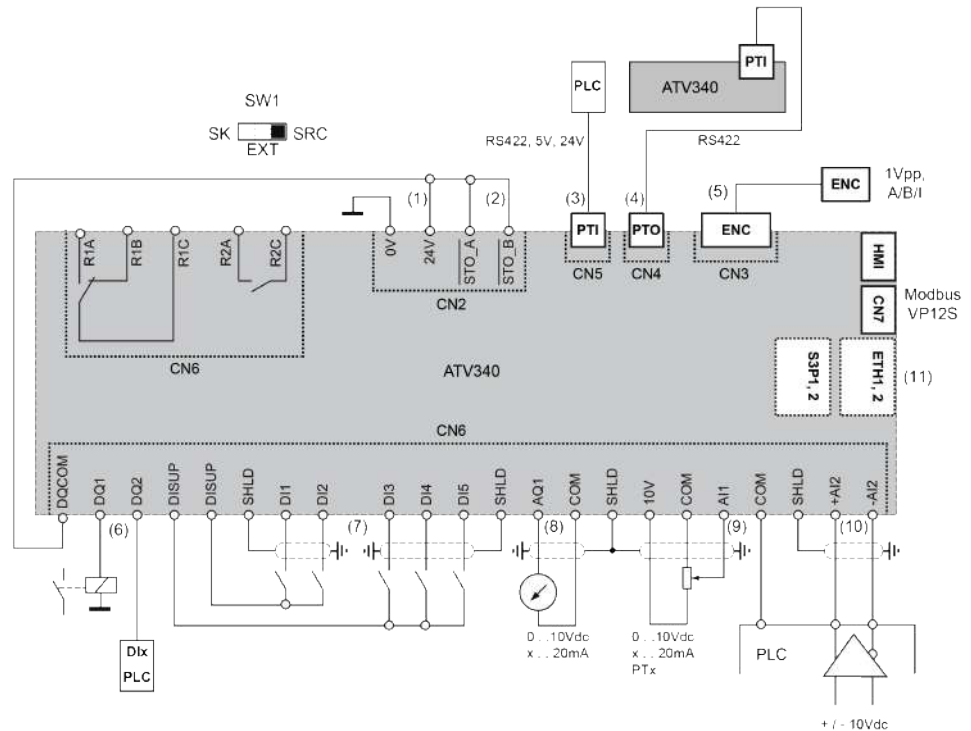

- (1) 24V In, Out, maximum supply current 200 mA is provided,
- (2) STO - Safe Torque Off, see ATV340 Embedded safety function manual NVE64143
- (3) PTI - Pulse Train In, from external source (eg.PLC) Pulse - Direction or A-B signals can be connected
- (4) PTO - Pulse Train Out, can be used to connect to a 2nd ATV340 PTI
- (5) To connect a motor position feedback encoder
- (6) Digital output, e.g. to connect a contactor, also usable as DI
- (7) Digital inputs
- (8) Analog output, e.g. to connect a meter
- (9) Analog input, e.g. from potentiometer
- (10) Differential analog input, e.g. as speed reference from external PLC differential, +/- 10 V
- (11) 2 advanced Ethernet ports ETH1, ETH2 (ATV340•••••E) or 2 Sercos III ports S3P1, S3P2 (ATV340•••••S)

## Three-phase Power Supply - Diagram With Line Contactor

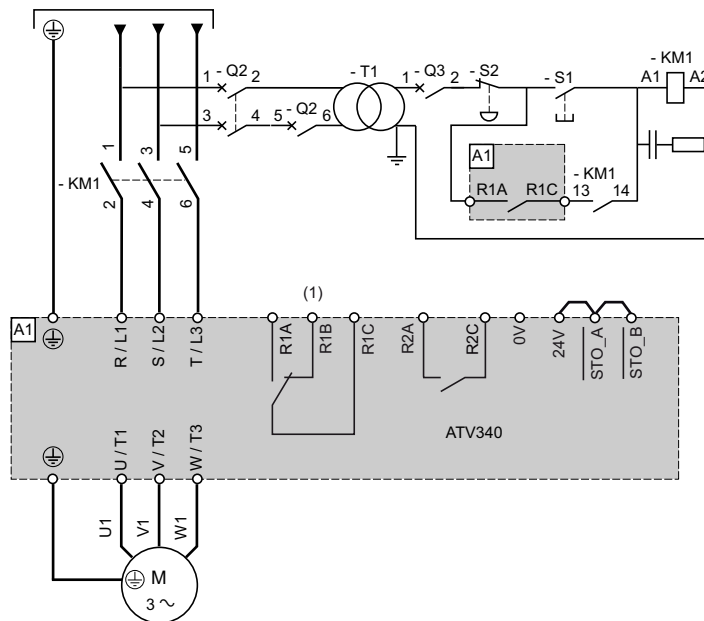

(1) Use relay output R1 set to operating state Fault to switch Off the product once an error is detected.

**NOTE:**

- Press S1 until the initialization of the drive is finished.
- An external 24V power supply can be connected so that the control part of the drive is always power supplied.

# Three-phase Power Supply - Diagram With Downstream Contactor

If a Run command is executed while the downstream contactor between the drive and the motor is still open, there may be residual voltage at the output of the drive. This can cause an incorrect estimation of the motor speed when the contacts of the downstream contactor are closed. This incorrect estimation of the motor speed can lead to unanticipated equipment operation or to equipment damage.

In addition, there may be overvoltage at the output of the drive if the power stage is still enabled when the downstream contactor between the drive and the motor opens.

**⚠ WARNING**

**UNANTICIPATED EQUIPMENT OPERATION OR EQUIPMENT DAMAGE**

If a downstream contactor is used between the drive and the motor, verify the following:

- The contacts between the motor and the drive must be closed before a Run command is executed.
- The power stage must not be enabled when the contacts between the motor and the drive open.

**Failure to follow these instructions can result in death, serious injury, or equipment damage.**

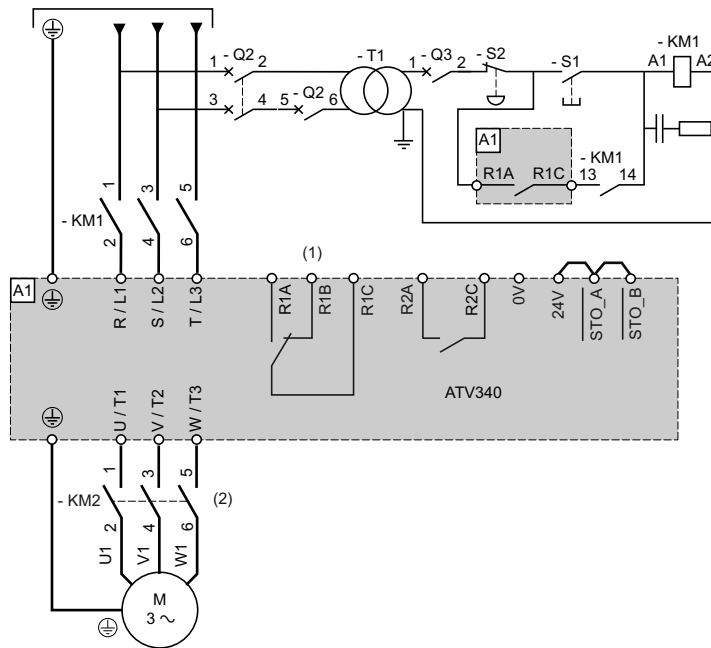

**(1)** Use relay output R1 set to operating state Fault to switch Off the product once an error is detected.

**(2)** Command of KM2 can be done by using the **[Output contactor cmd]** occ function. For more information, refer to the programming manual.

**NOTE:**

- Close upstream contactor, then press S1 after the initialization of the drive is finished.
- An external 24V power supply can be connected so that the control part of the drive is always power supplied.

## Safety Function STO

All details related to the STO safety function activation are given in the Embedded Safety function manual NVE64143.

## Sensor Connection

It is possible to connect either 1 sensor on terminals AI1 or AI3.

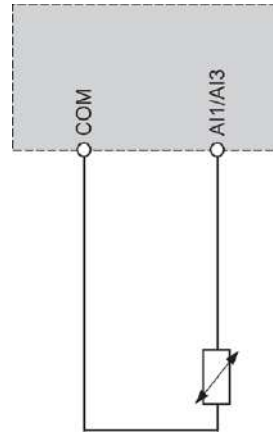

# Wiring Diagrams for Frame Sizes 4 and 5: ATV340D30N4E...D75N4E

## Control Block Wiring Diagram

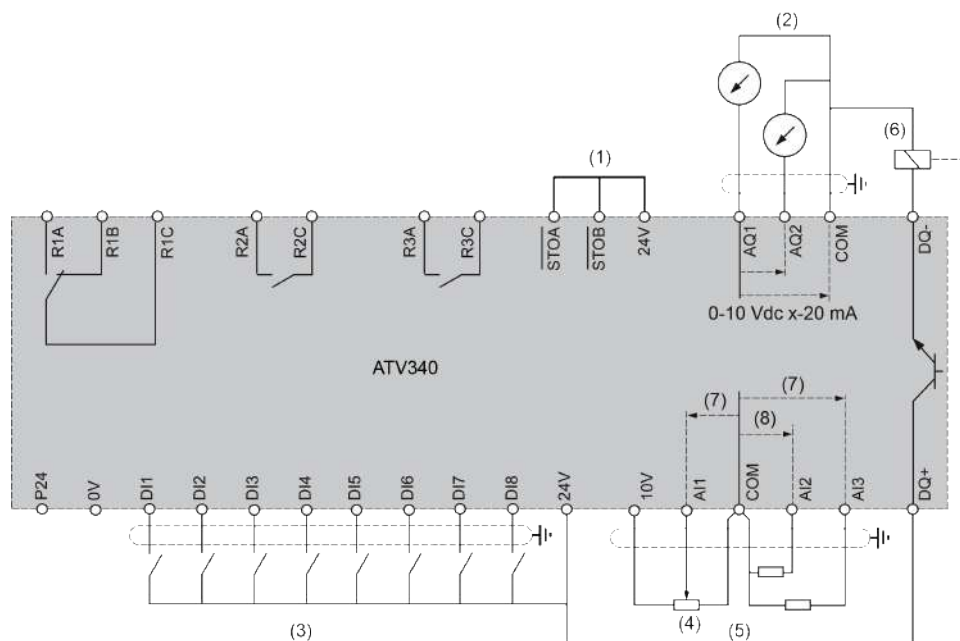

- (1) STO Safe Torque Off
- (2) Analog Output
- (3) Digital Input - Shielding instructions are given in the Electromagnetic Compatibility section
- (4) Reference potentiometer (ex. SZ1RV1002)
- (5) Analog Input
- (6) Digital output
- (7) 0-10 Vdc, x-20 mA
- (8) 0-10 Vdc, -10 Vdc...+10 Vdc

**NOTE:** PTI function is not available on frame sizes 4 and 5.

## Three-phase Power Supply - Diagram With Line Contactor

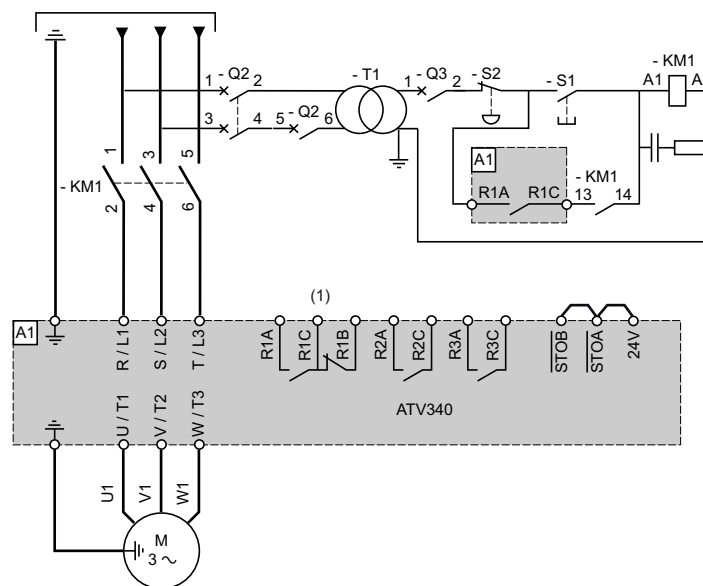

(1) Use relay output R1 set to operating state Fault to switch Off the product once an error is detected.

**NOTE:**

- Press S1 until the initialization of the drive is finished.
- An external 24V power supply can be connected so that the control part of the drive is always power supplied.

# Three-phase Power Supply - Diagram With Downstream Contactor

If a Run command is executed while the downstream contactor between the drive and the motor is still open, there may be residual voltage at the output of the drive. This can cause an incorrect estimation of the motor speed when the contacts of the downstream contactor are closed. This incorrect estimation of the motor speed can lead to unanticipated equipment operation or to equipment damage.

In addition, there may be overvoltage at the output of the drive if the power stage is still enabled when the downstream contactor between the drive and the motor opens.

**⚠ WARNING**

**UNANTICIPATED EQUIPMENT OPERATION OR EQUIPMENT DAMAGE**

If a downstream contactor is used between the drive and the motor, verify the following:

- The contacts between the motor and the drive must be closed before a Run command is executed.
- The power stage must not be enabled when the contacts between the motor and the drive open.

**Failure to follow these instructions can result in death, serious injury, or equipment damage.**

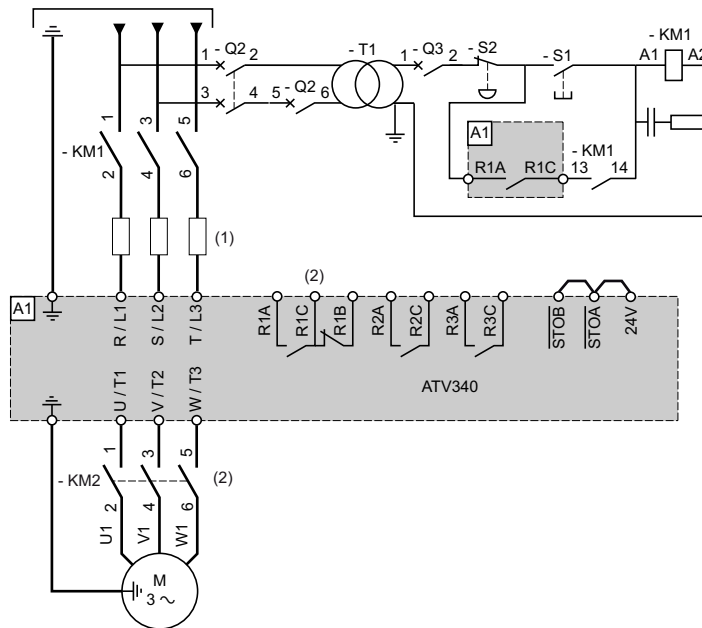

**(1)** Use relay output R1 set to operating state Fault to switch Off the product once an error is detected.

**(2)** Command of KM2 can be done by using the **[Output contactor cmd]** occ function. For more information, refer to the programming manual.

**NOTE:**

- Close upstream contactor, then press S1 after the initialization of the drive is finished.
- An external 24V power supply can be connected so that the control part of the drive is always power supplied.

## Safety Function STO

All details related to the STO safety function activation are given in the Embedded Safety function manual NVE64143.

## Sensor Connection

It is possible to connect either 1 sensor on terminals AI1 or AI3.

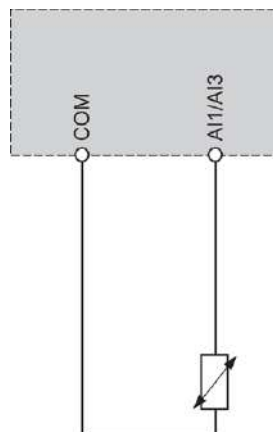

# Built-in EMC Filter

## What's in This Chapter

Operation on an IT System.....	105
Disconnecting the Built-in EMC Filter .....	105

## Operation on an IT System

### Definition

**IT system:** Isolated or impedance grounded neutral. Use a permanent insulation monitoring device compatible with nonlinear loads, such as an XM200 type or equivalent.

### Operation

#### **NOTICE**

##### **OVERVOLTAGE OR OVERHEATING**

If the drive is operated via an IT or corner grounded system, the integrated EMC filter must be disconnected as described in the present manual.

**Failure to follow these instructions can result in equipment damage.**

## Disconnecting the Built-in EMC Filter

### Filter Disconnection

#### **⚠️⚠️ DANGER**

##### **HAZARD OF ELECTRIC SHOCK, EXPLOSION OR ARC FLASH**



Read and understand the instructions in **Product Related Information** chapter before performing any procedure in this chapter.

**Failure to follow these instructions will result in death or serious injury.**

The drives have a built-in EMC filter. As a result they exhibit leakage current to ground. If the leakage current creates compatibility problems with your installation (residual current device or other), then you can reduce the leakage current by deactivating the Y capacitors as shown below. In this configuration the product does not meet the EMC requirements according to the standard IEC 61800-3.

## Setting on Frame Sizes 1 and 2

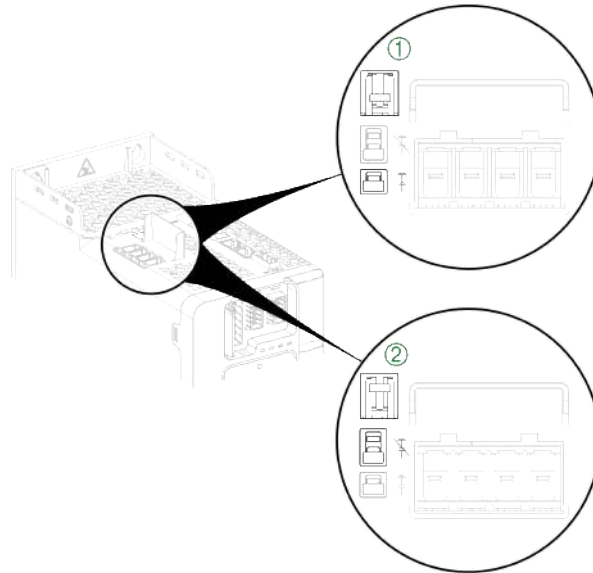

Apply the following instructions to disconnect the built-in EMC filter

Step	Action
1	The switch is <b>factory set</b> to the  position as shown on detail ①
2	To disconnect the built-in EMC filter  use a screwdriver to set the switch to the position shown on detail ②



## Setting on Frame Size 3

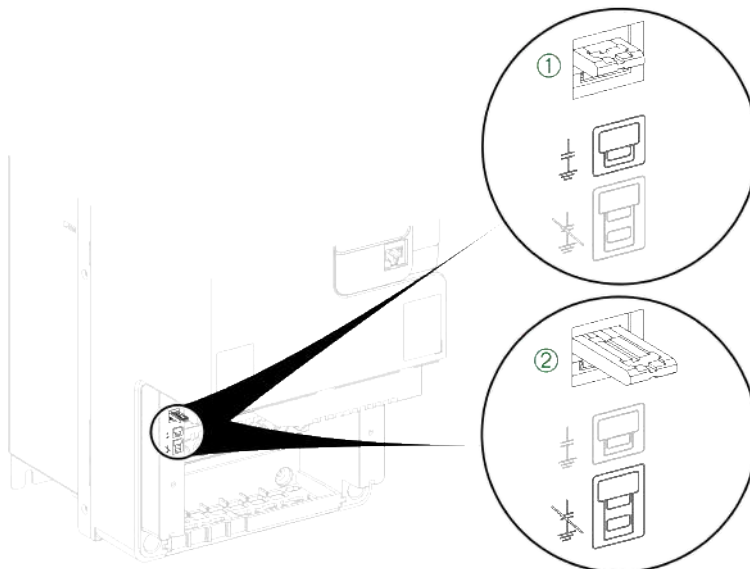

Apply the following instructions to disconnect the built-in EMC filter

Step	Action
1	Remove the front cover.
2	The switch is <b>factory set</b> to the  position as shown on detail ①
3	To disconnect the built-in EMC filter  use a screwdriver to set the switch to the position shown on detail ②
4	Refit the front cover.



## Setting on Frame Sizes 4 and 5

Apply the following instructions to disconnect the built-in EMC filter

Step	Action
1	Remove the front cover , page 122
2	The screw is <b>factory set</b> to the  position as shown on detail ①
3	To disconnect the built-in EMC filter, remove the screw from its location and set it to the  position as shown on detail ②
4	Refit the front cover

**NOTE:**

- Use only the screws supplied.
- Do not operate the drive with setting screws removed.

**Setting on Frame Size 4, 200...240 V Products**

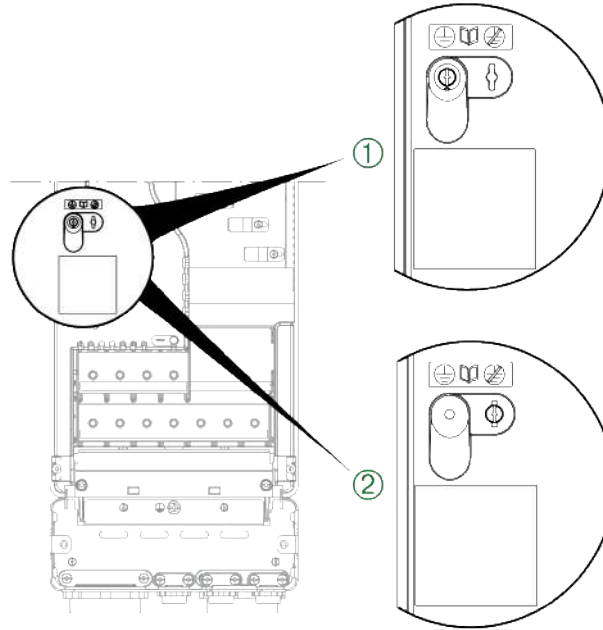

**Setting on Frame Size 4, 380...480 V Products**

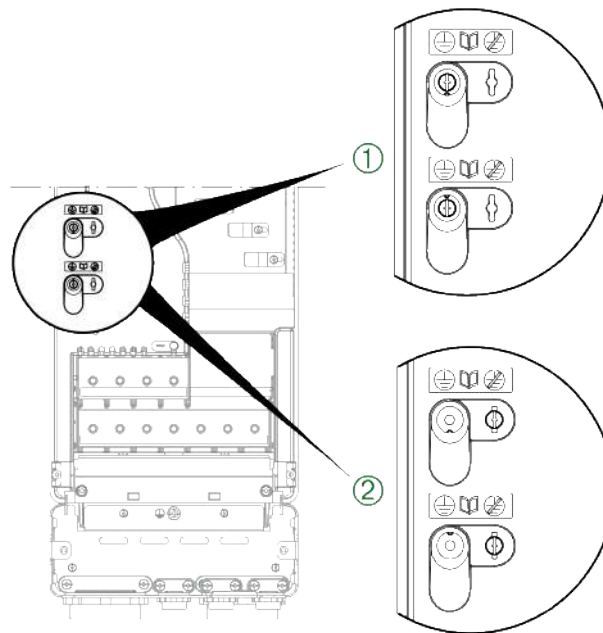

### Setting on Frame Size 5 Products

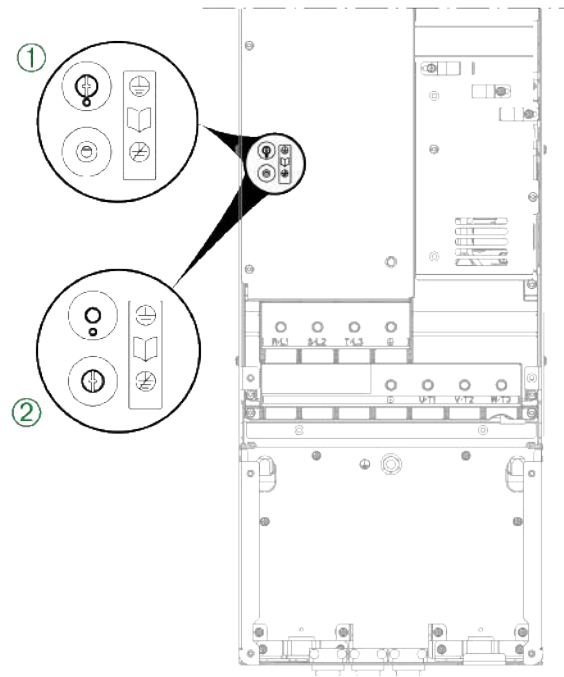

# Power Part

## What's in This Chapter

Characteristics of the Power Part Terminals.....	111
Wiring the Power Part.....	117

## Characteristics of the Power Part Terminals

**⚠️⚠️ DANGER**

**HAZARD OF FIRE OR ELECTRIC SHOCK**

- Wire cross sections and tightening torques must comply with the specifications provided in this document.
- If you use flexible multi-wire cables for a connection with a voltage higher than 25 Vac, you must use ring type cable lugs or wire ferrules, depending on the wire gauge and the specified stripping length of the cable.

**Failure to follow these instructions will result in death or serious injury.**

Impact wrench cannot be used to ensure correct tightening torque and can cause damage to the fastener and/or equipment.

## Description of the Power Terminals

Terminal	Function
PE or 	Ground connection terminal
R/L1 S/L2 T/L3	AC supply mains
PA/+	DC bus + polarity (Output to braking resistor)
PB (if any)	Output to braking resistor
PC/-	DC bus - polarity
U/T1 V/T2 W/T3	Outputs to the motor

## Ground Connection Cables

Ground cable cross sections of input and output ground cables are the same as those given for the input and output cables. These cross sections and related tightening torques are given in the tables below.

## Protective earth ground cables

**⚠️⚠️ DANGER**

**ELECTRIC SHOCK CAUSED BY INSUFFICIENT GROUNDING**

- For the protective earth conductor connected to the grounding screw, verify that the minimum cross section is compliant with the next table.
- Verify compliance with all local and national electrical code requirements as well as all other applicable regulations with respect to grounding of the entire drive system.

**Failure to follow these instructions will result in death or serious injury.**

Cross-sectional area of phase conductors of the product S (mm <sup>2</sup> ) (for copper cables)	Minimum cross-sectional area of the corresponding protective earthing conductor Sp (mm <sup>2</sup> ) (for copper cables)
S ≤ 10	10
10 < S ≤ 16	S
16 < S ≤ 35	16
35 < S	S/2

## Cross Section: Electrical and Mechanical characteristics

**⚡⚠ DANGER**

**HAZARD OF FIRE OR ELECTRIC SHOCK**

If the product is used below its rated power and you choose to reduce the wire cross section compared to the specified minimum wire cross section given at rated condition, ensure that the selected wire cross section is compliant with the duty cycle and current load of the application.

**Failure to follow these instructions will result in death or serious injury.**

## Frame Size 1

### Electrical characteristics (\*)

ATV340	Minimum Wire Cross Section at rated condition		
	Supply Terminals (L1, L2, L3, PE) CN1 Connector	Output Terminals (U, V, W, PBe) CN10 Connector	DC Bus Terminals (**) (PA/+, PC/-) CN9 connector
	mm <sup>2</sup> (AWG)	mm <sup>2</sup> (AWG)	mm <sup>2</sup> (AWG)
	U07N4*, U15N4*, U22N4*, U30N4*, U40N4*	4 (12)	4 (12)

(\*) Minimum wire cross section to be applied when the product is used at rated power.  
 (\*\*) Wire cross section in case of DC bus voltage supply

### Mechanical characteristics

ATV340	Supply Terminals (L1, L2, L3, PE) CN1 Connector				DC Bus Terminals (PA/+, PC/-) CN9 connector (***)			
	Output Terminals (U, V, W, PBe) CN10 Connector							
	Minimum (*)		Maximum		Minimum (*)		Maximum	
	Permissible Cross Section (**)	Rated Tightening Torque	Permissible Cross Section	Rated Tightening Torque	Permissible Cross Section (**)	Rated Tightening Torque	Permissible Cross Section	Rated Tightening Torque
mm <sup>2</sup> (AWG)	N·m (lbf.in)	mm <sup>2</sup> (AWG)	N·m (lbf.in)	mm <sup>2</sup> (AWG)	N·m (lbf.in)	mm <sup>2</sup> (AWG)	N·m (lbf.in)	
U07N4*, U15N4*, U22N4*, U30N4*, U40N4*	0.5 (20)	1.3 (11.5)	6 (8)	0.69 (6.1)	0.5 (20)	1.3 (11.5)	6 (10)	1.8 (15.6)

(\*) The mechanical characteristics concern power terminal only and do not take into account the cabling equipment (cable clamp, cable gland,...) that are designed for the rated conditions.  
 (\*\*) Minimum permissible cross section are provided, if the product is used below its rated power. In this case, ensure that the wire cross section is compliant with the duty cycle and current load.  
 (\*\*\*) Wire cross section in case of DC bus voltage supply

**NOTE:** Only use cables with solid wires or rigid stranded wires.

## Frame Size 2

### Electrical characteristics (\*)

ATV340	Minimum Wire Cross Section at rated condition		
	Supply Terminals (L1, L2, L3, PE) CN1 Connector	Output Terminals (U, V, W, PBe) CN10 Connector	DC Bus Terminals (**) (PA/+, PC/-) CN9 connector
	mm <sup>2</sup> (AWG)	mm <sup>2</sup> (AWG)	mm <sup>2</sup> (AWG)
	U55N4•, U75N4•	6 (8)	6 (8)
(*) Minimum wire cross section to be applied when the product is used at rated power.			
(**) Wire cross section in case of DC bus voltage supply			

### Mechanical characteristics

ATV340	Supply Terminals (L1, L2, L3, PE) CN1 Connector Output Terminals (U, V, W, PBe) CN10 Connector				DC Bus Terminals (PA/+, PC/-) CN9 connector (***)			
	Minimum (*)		Maximum		Minimum (*)		Maximum	
	Permissible Cross Section (**)	Rated Tightening Torque	Permissible Cross Section	Rated Tightening Torque	Permissible Cross Section (**)	Rated Tightening Torque	Permissible Cross Section	Rated Tightening Torque
	mm <sup>2</sup> (AWG)	N·m (lbf.in)	mm <sup>2</sup> (AWG)	N·m (lbf.in)	mm <sup>2</sup> (AWG)	N·m (lbf.in)	mm <sup>2</sup> (AWG)	N·m (lbf.in)
U55N4•, U75N4•	0.5 (20)	1.8 (15.6)	10 (6)	1.8 (15.6)	0.5 (20)	1.8 (15.6)	6 (10)	1.8 (15.6)
(*) The mechanical characteristics concern power terminal only and do not take into account the cabling equipment (cable clamp, cable gland,...) that are designed for the rated conditions.								
(**) Minimum permissible cross section are provided, if the product is used below its rated power. In this case, ensure that the wire cross section is compliant with the duty cycle and current load.								
(***) Wire cross section in case of DC bus voltage supply								

**NOTE:** Only use cables with solid wires or rigid stranded wires.

#### Tightening torques of additional PE:

- Upper ground connection: 2.6 N·m (23.01 lb.in) - CN1 connector
- Lower ground connection: 0.69 N·m (6.1 lb.in) - CN10 connector

## Frame Size 3

### Electrical characteristics (\*)

ATV340	Minimum Wire Cross Section at rated condition		
	Supply Terminals (L1, L2, L3, PE) CN1 Connector	Output Terminals (U, V, W, PBe) CN10 Connector	DC Bus Terminals (**) (PA/+, PC/-) CN9 connector
	mm <sup>2</sup> (AWG)	mm <sup>2</sup> (AWG)	mm <sup>2</sup> (AWG)
	D11N4•	10 (8)	10 (8)
D15N4•	16 (6)	16 (6)	16 (6)
D18N4•	16 (4)	16 (4)	16 (4)
D22N4•	25 (3)	25 (3)	25 (3)
(*) Minimum wire cross section to be applied when the product is used at rated power.			
(**) Wire cross section in case of DC bus voltage supply			

**Mechanical characteristics**

ATV340	Supply Terminals (L1, L2, L3, PE) CN1 Connector Output Terminals (U, V, W, PBe) CN10 Connector DC Bus Terminals (PA/+, PC/-) CN9 connector (***)			
	Minimum (*)		Maximum	
	Permissible Cross Section (**)	Rated Tightening Torque	Permissible Cross Section	Rated Tightening Torque
	mm <sup>2</sup> (AWG)	N·m (lbf.in)	mm <sup>2</sup> (AWG)	N·m (lbf.in)
D11N4• D15N4• D18N4• D22N4•	0.5 (20)	3.5 (30.4)	25 (3)	3.8 (33.6)
(*) The mechanical characteristics concern power terminal only and do not take into account the cabling equipment (cable clamp, cable gland,...) that are designed for the rated conditions. (**) Minimum permissible cross section are provided, if the product is used below its rated power. In this case, ensure that the wire cross section is compliant with the duty cycle and current load. (***) Wire cross section in case of DC bus voltage supply				

**NOTE:** Only use cables with solid wires or rigid stranded wires.

**Tightening torques of additional PE:**

- Upper ground connection: 2.6 N·m (23.01 lb.in) - CN1 connector
- Lower ground connection: 0.69 N·m (6.1 lb.in) - CN10 connector

**Frame Size 4****Electrical characteristics (\*)**

ATV340	Minimum Wire Cross Section at rated condition		
	Supply Terminals (L1, L2, L3, PE)	Output Terminals (U, V, W, PE)	DC Bus Terminals (**) (PA/+, PC/-)
	mm <sup>2</sup> (AWG)	mm <sup>2</sup> (AWG)	mm <sup>2</sup> (AWG)
D30N4E•	35 (3)	35 (3)	25 (4)
D37N4E•	35 (2)	50 (1)	35 (3)
(*) Minimum wire cross section to be applied when the product is used at rated power. (**) Wire cross section in case of DC bus voltage supply			

**Mechanical characteristics**

ATV340	Supply Terminals (L1, L2, L3, PE)			
	Output Terminals (U, V, W, PE)			
	DC Bus Terminals (PA/+, PC/-) (***)			
	Minimum (*)		Maximum	
Permissible Cross Section (**)	Rated Tightening Torque	Permissible Cross Section	Rated Tightening Torque	
mm <sup>2</sup> (AWG)	N·m (lbf.in)	mm <sup>2</sup> (AWG)	N·m (lbf.in)	
D30N4E• D37N4E•	16 (6)	12 (106.2)	50 (1)	12 (106.2)

(\*) The mechanical characteristics concern power terminal only and do not take into account the cabling equipment (cable clamp, cable gland,...) that are designed for the rated conditions.

(\*\*) Minimum permissible cross section are provided, if the product is used below its rated power. In this case, ensure that the wire cross section is compliant with the duty cycle and current load.

(\*\*\*) Wire cross section in case of DC bus voltage supply

**NOTE:** Only use cables with solid wires or rigid stranded wires.  
**Tightening torque of additional PE:** 5 N·m (44.2 lb.in)

**Frame Size 5**

**Electrical characteristics (\*)**

ATV340	Minimum Wire Cross Section at rated condition		
	Supply Terminals (L1, L2, L3, PE)	Output Terminals (U, V, W, PE)	DC Bus Terminals (**)
	mm <sup>2</sup> (AWG)	mm <sup>2</sup> (AWG)	mm <sup>2</sup> (AWG)
D45N4E•	70 (1/0)	70 (1/0)	70 (1/0)
D55N4E•	95 (3/0)	95 (3/0)	70 (1/0)
D75N4E•	120 (4/0)	120 (250MCM)	95 (3/0)

(\*) Minimum wire cross section to be applied when the product is used at rated power.

(\*\*) Wire cross section in case of DC bus voltage supply

**Mechanical characteristics**

ATV340	Supply Terminals (L1, L2, L3, PE) Output Terminals (U, V, W, PE) DC Bus Terminals (PA/+, PC/-) (***)			
	Minimum (*)		Maximum	
	Permissible Cross Section (**)	Rated Tightening Torque	Permissible Cross Section	Rated Tightening Torque
	mm <sup>2</sup> (AWG)	N·m (lbf.in)	mm <sup>2</sup> (AWG)	N·m (lbf.in)
D45N4E• D55N4E• D75N4E•	16 (4)	25 (221.3)	120 (250MCM)	25 (221.3)
<p>(*) The mechanical characteristics concern power terminal only and do not take into account the cabling equipment (cable clamp, cable gland,...) that are designed for the rated conditions.</p> <p>(**) Minimum permissible cross section are provided, if the product is used below its rated power. In this case, ensure that the wire cross section is compliant with the duty cycle and current load.</p> <p>(***) Wire cross section in case of DC bus voltage supply</p>				

**NOTE:** Only use cables with solid wires or rigid stranded wires.

**Tightening torque of additional PE:** 10 N·m (88.5 lb.in)

# Wiring the Power Part

## ⚠️⚠️ DANGER

**HAZARD OF ELECTRIC SHOCK, EXPLOSION OR ARC FLASH**

- Verify that the cables are properly installed as specified.
- Ensure protection against contact with live parts in the entire installation, including cables.
- Ensure adequate sealing of the cable entries.
- Before commissioning, verify that the degree of protection specified on the nameplate and in all pertinent product documentation is achieved.

**Failure to follow these instructions will result in death or serious injury.**

## Power Terminals Arrangement for Frame Sizes 1...2

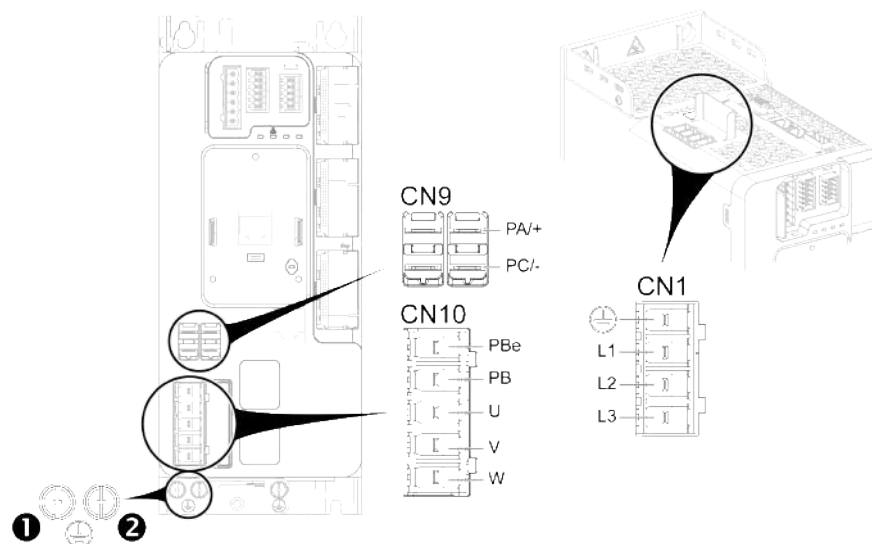

## Functions of the Power Terminals

Terminal	Connector (on frame sizes 1...2)	Function
L3/T - L2/S - L1/R - ⚡	CN1	Mains supply and Input ground terminal
PA/+	CN9	DC bus + polarity
PC/-	CN9	DC bus - polarity
W/T3 - V/T2 - U/T1 - PB - PBe	CN10	Output motor connection W/T3 - V/T2 - U/T1, output to braking resistor (1) PB - PBe
⚡		Output ground terminal <b>1</b> and braking resistor ground terminal <b>2</b>
<b>(1)</b> For further information about the braking resistor option, please refer to the <a href="#">catalog</a> .		

## Additional PE Ground Terminal Connection

Connect the additional PE ground terminal of the device to the central grounding point of the system.

Additional PE ground terminal location on frame sizes 1 and 2

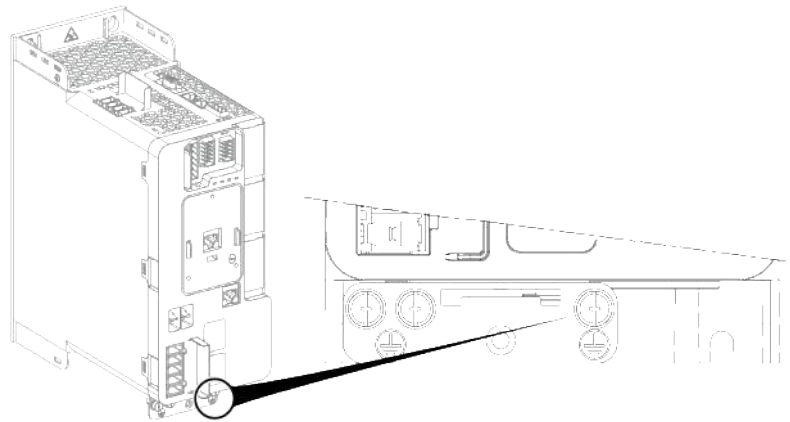

## Access To The Terminals For Frame Size 3

### ⚡ ⚠ DANGER

**HAZARD OF ELECTRIC SHOCK, EXPLOSION OR ARC FLASH**

Read and understand the instructions in **Product Related Information** chapter before performing any procedure in this chapter.

**Failure to follow these instructions will result in death or serious injury.**

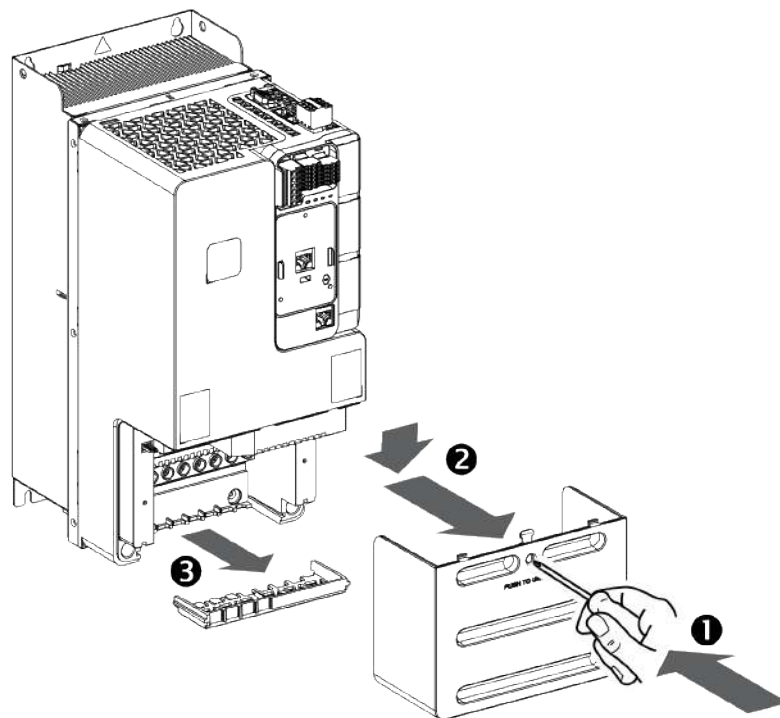

Apply the following instructions to access the terminals on **frame size 3** drives

Step	Action
1	Using a screwdriver, push to unlock the cover
2	Remove the front cover
3	Remove the wiring trap

## Power Terminals Arrangement for Frame Size 3

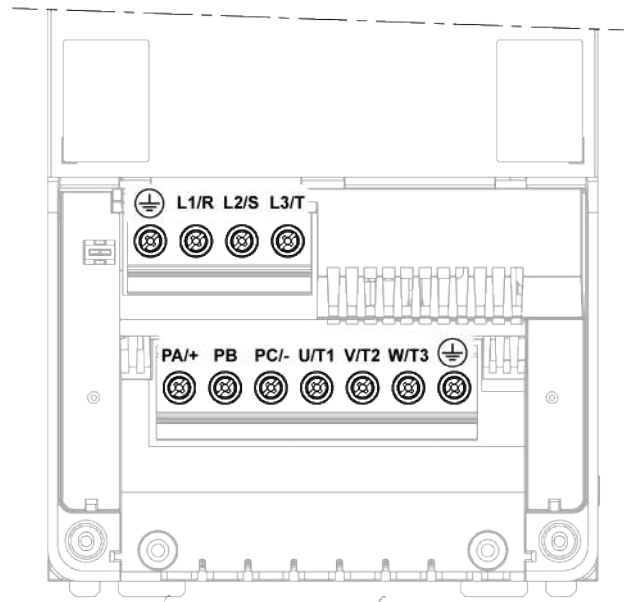

## Additional PE Ground Terminal Connection

Connect the ground terminal of the device to the central grounding point of the system.

Additional PE ground terminal location on frame sizes 3

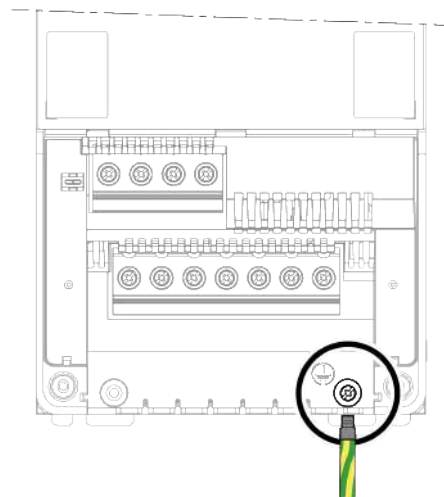

Use the special ring tongue cable end.

## Power Cables Routing

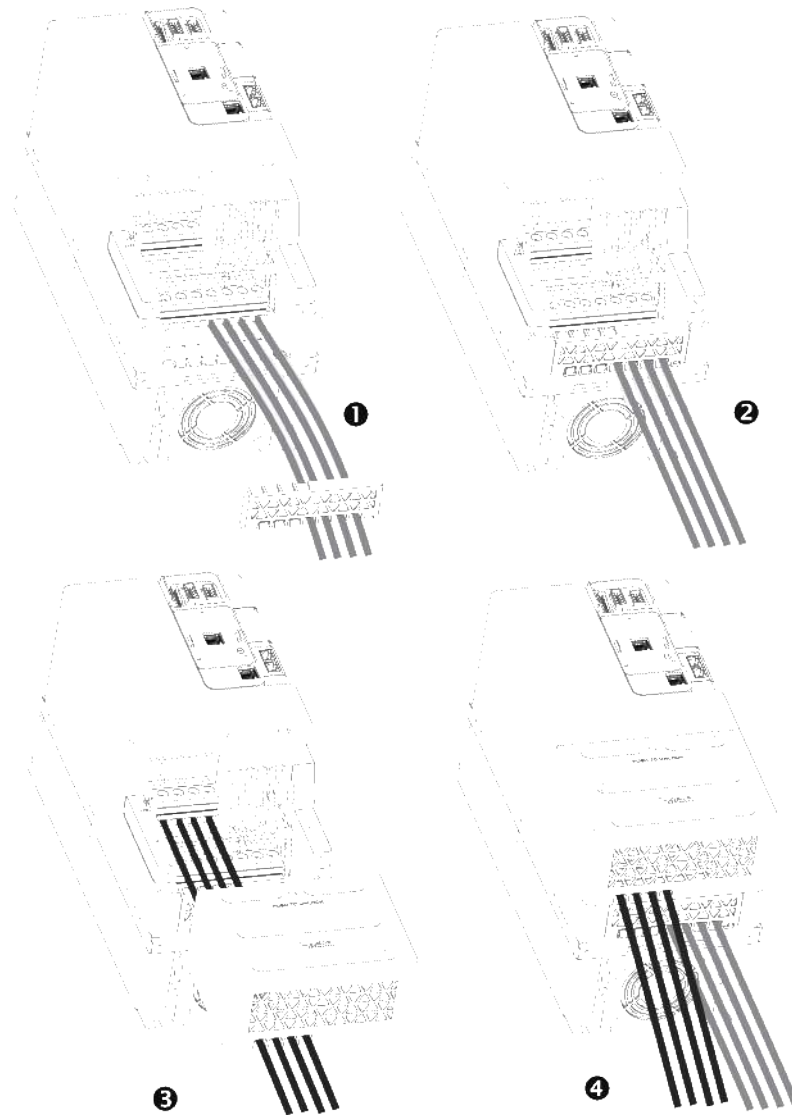

Perform the following instructions

Step	Action
1	Attach and route the motor cable
2	Refit the wiring trap
3	Attach and route the mains cable
4	Refit the power cover

## Power Cables Attaching

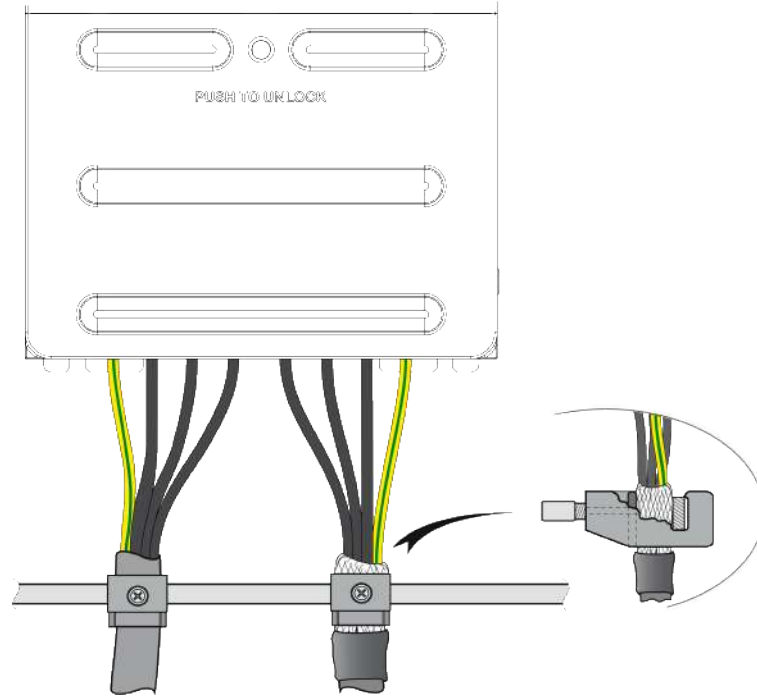

## Access To The Terminals For Frame Sizes 4 and 5

### **⚡ ⚠ DANGER**

#### **HAZARD OF ELECTRIC SHOCK, EXPLOSION OR ARC FLASH**

Read and understand the instructions in **Product Related Information** chapter before performing any procedure in this chapter.

**Failure to follow these instructions will result in death or serious injury.**

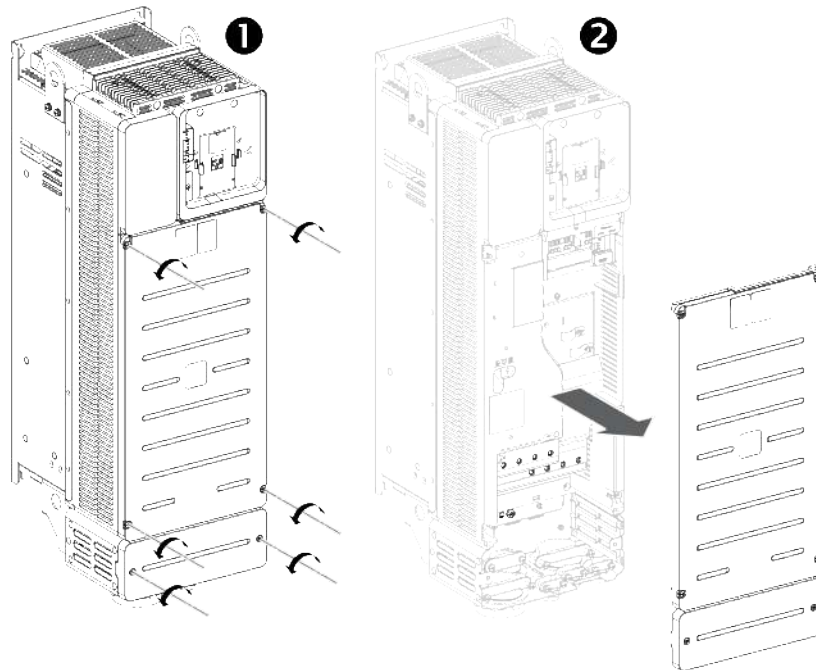

Apply the following instructions to access the terminals on **frame sizes 4 and 5** drives

Step	Action
1	Unscrew the 6 screws attaching the housing
2	Remove the front covers

## Additional PE Ground Terminal Connection

Connect the ground terminal of the device to the central grounding point of the system.

Additional PE ground terminal location on frame sizes 4 and 5

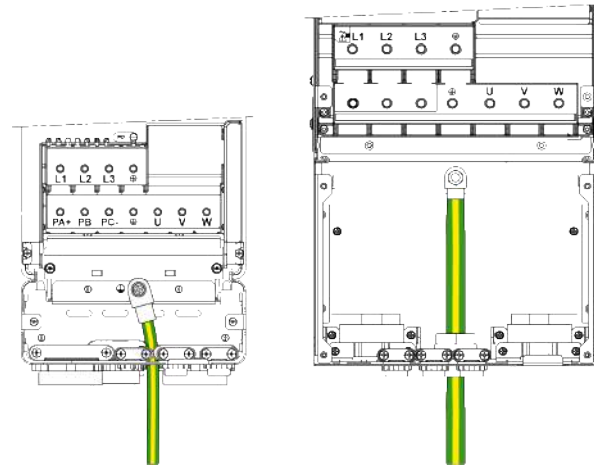

## Power Terminals Arrangement for Frame Size 4 and 5 and Cable Path

Wire the power cables as shown below.

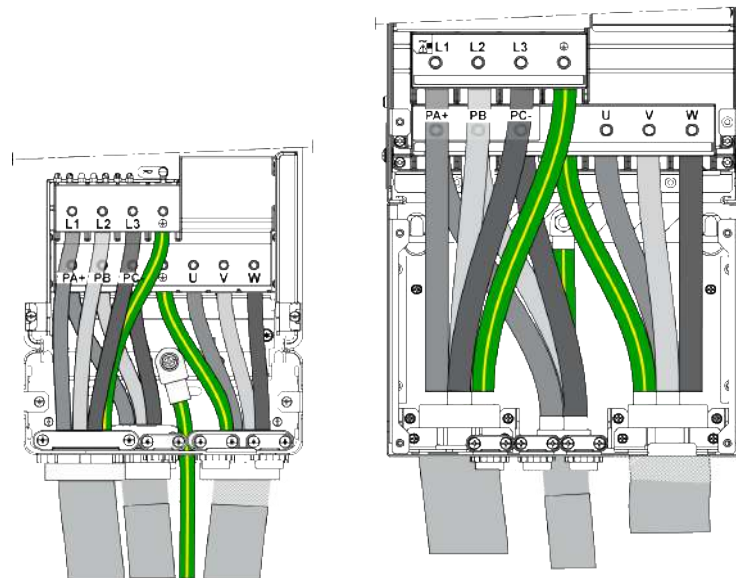

# Control Part

## What's in This Chapter

Arrangement and Characteristics of Control Block Terminals, Communication and I/O Ports.....	125
Control Terminals Electrical Data for Frame Sizes 1...3 .....	130
Control Terminals Electrical data for Frame Sizes 4 and 5.....	142
Wiring The Control Part of Frame Sizes 4 and 5.....	146
Product LEDs.....	153

# Arrangement and Characteristics of Control Block Terminals, Communication and I/O Ports

## Cable lengths

**NOTE:** For cable lengths, refer to the table given in the Cable Length Instructions For the Control Part section, page 90.

## Front Control Terminals - Drive Frame Sizes 1...3

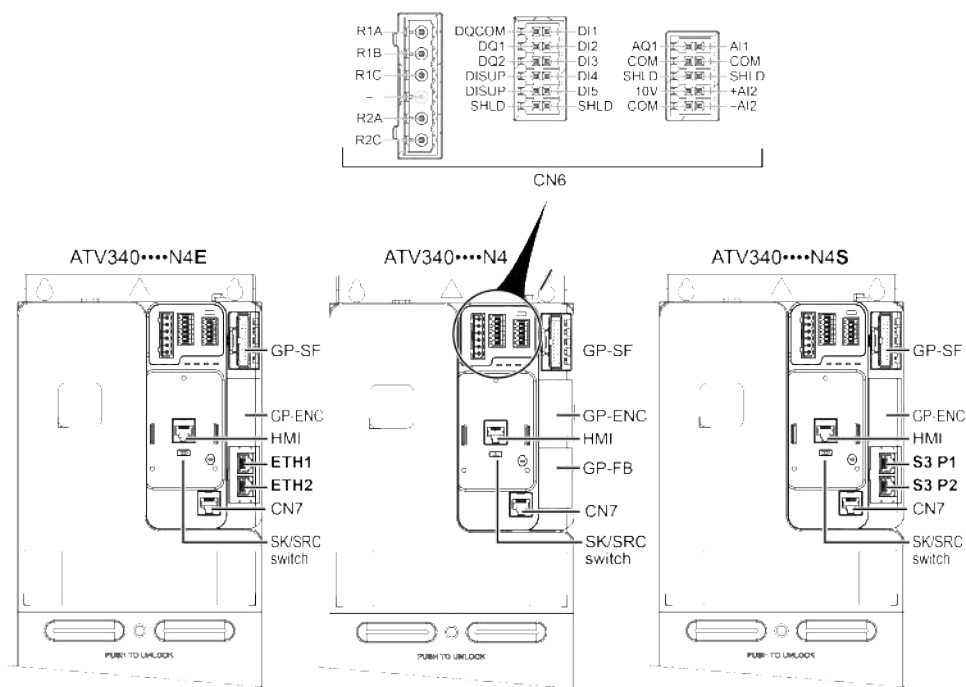

Connector / Switch	Description
GP-SF	Slot for safety and general purpose modules like I/O, Relay
GP-ENC	Slot for encoder module. Use only VW3A3420, VW3A3422, VW3A3423 or VW3A3424 modules and general purpose modules like I/O, Relay
HMI	RJ45 port for Plain Text Display Terminal (VW3A1113) direct plug-in or Graphic Display Terminal (VW3A1111) to connect with a cable , page 29
ETH1, ETH2	2 x RJ45 Advanced Ethernet ports, on ATV340...E
S3 P1, S3 P2	2 x RJ45 Embedded Sercos III ports, on ATV340...S
GP-FB	Slot for fieldbus and general purpose modules like IO, Relay
CN7	Modbus VP12S port, page 141
SK/EXT/SRC switch	Sink-Source switch, page 157
CN6	Analog and digital I/O, relay outputs..., page 138

## Top Control Terminals Location on Drive Frame Sizes 1...3

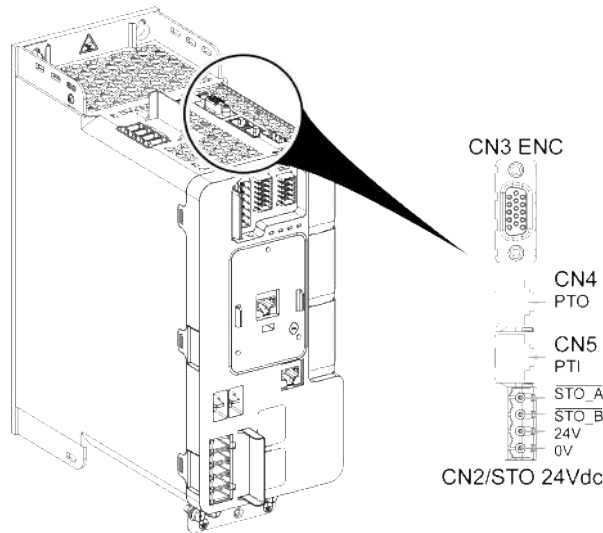

Connector / Switch	Description
CN3 ENC	Embedded encoder, page 132 <b>NOTE:</b> An additional clearance is required on top of the drive when using the embedded encoder.
CN4	PTO (Pulse Train Output), page 134
CN5	PTI (Pulse Train Input), page 134
CN2/STO 24Vdc	STO (Safe Torque Off), page 131

## Wiring Characteristics - Drive Frame Sizes 1...3

⚡ ⚠ **DANGER**

**HAZARD OF FIRE OR ELECTRIC SHOCK**

- Wire cross sections and tightening torques must comply with the specifications provided in this document.
- If you use flexible multi-wire cables for a connection with a voltage higher than 25 Vac, you must use ring type cable lugs or wire ferrules, depending on the wire gauge and the specified stripping length of the cable.

**Failure to follow these instructions will result in death or serious injury.**

Wire cross sections and tightening torques. Cross section values are with ferrule.

Control Terminals	Relay Output Wire Cross Section		Other Wire Cross Section		Tightening Torque Rnx
	Minimum (1)	Maximum	Minimum (1)	Maximum	
	mm <sup>2</sup> (AWG)	mm <sup>2</sup> (AWG)	mm <sup>2</sup> (AWG)	mm <sup>2</sup> (AWG)	
CN6 terminals	0.25 (24)	2.5 (14)	0.25 (24)	1 (16)	0.5 (4.4)

(1) The value corresponds to the minimum permissible cross section of the terminal.

**NOTE:** Control Terminal Electrical data., page 130

## Control Terminals - Drive Frame Sizes 4 and 5

The control block terminals are the same for drive frame sizes 4 and 5.

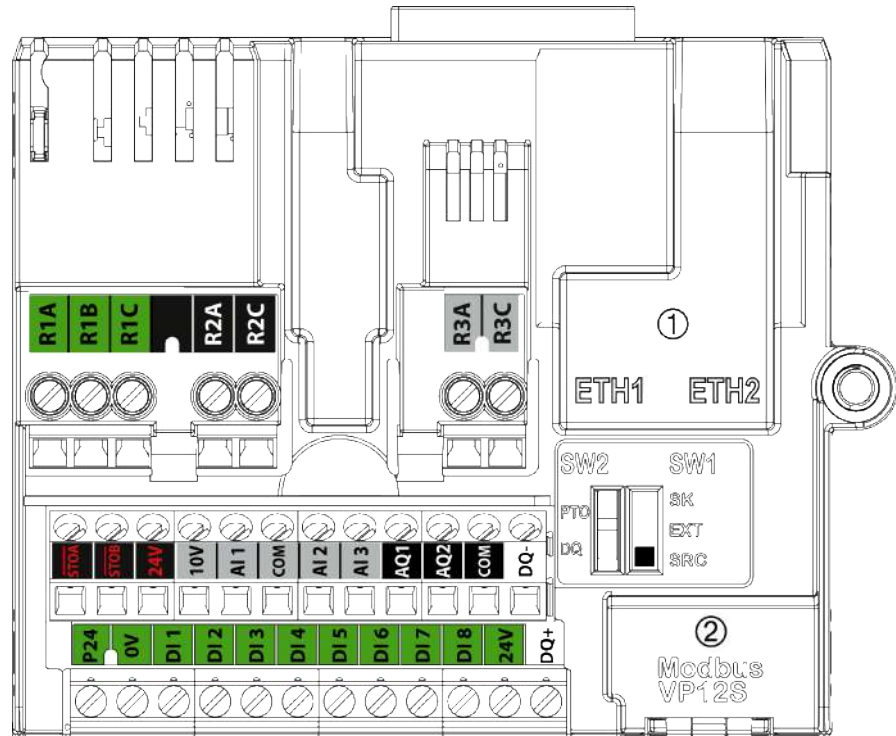

① Ethernet Modbus TCP, ② Serial Modbus

**NOTE:** Modbus VP12S: This is the standard Modbus serial link marking. VP•S means connector with power supply, where 12 stands for the 12 Vdc supply voltage.

## Wiring Characteristics Drive Frame Sizes 4 and 5

**⚠️ DANGER**

**HAZARD OF FIRE OR ELECTRIC SHOCK**

- Wire cross sections and tightening torques must comply with the specifications provided in this document.
- If you use flexible multi-wire cables for a connection with a voltage higher than 25 Vac, you must use ring type cable lugs or wire ferrules, depending on the wire gauge and the specified stripping length of the cable.

**Failure to follow these instructions will result in death or serious injury.**

Wire cross sections and tightening torques.

Control Terminals	Relay Output Wire Cross Section		Other Wire Cross Section		Tightening Torque
	Minimum (1)	Maximum	Minimum (1)	Maximum	
	mm <sup>2</sup> (AWG)	mm <sup>2</sup> (AWG)	mm <sup>2</sup> (AWG)	mm <sup>2</sup> (AWG)	
All terminals	0.75 (18)	1.5 (16)	0.5 (2.0)	1.5 (16)	0.5 (4.4)

(1) The value corresponds to the minimum permissible cross section of the terminal.

**NOTE:** Control Terminal Electrical data., page 130

## Control Block Ports

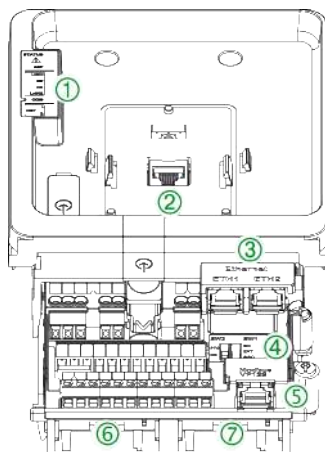

### Legend

Mark- ing	Description
①	Drive status LEDs, page 153
②	RJ45 port to plug directly a plain text display terminal or using a cable to connect a Graphic display terminal
③	2 x RJ45 ports: ETH1 and ETH2 for Ethernet embedded
④	SK-EXT-SRC switch SW1, page 157 PTO-DQ switch SW2, page 161
⑤	RJ45 port for Modbus embedded
⑥	Slot B, for encoder interface, and GP (general purpose) modules like I/O, Relay...
⑦	Slot A, for fieldbus communication and GP (general purpose) modules like I/O, Relay...

## Optional Module Installation and Wiring

### NOTE:

- For possible fieldbus module list, refer to the catalog.
- For fieldbus modules information, refer to the instruction sheet S1A45591 available on [www.se.com](http://www.se.com).

## RJ45 Communication ports

The control block includes 4 RJ45 ports.

They allow to connect a:

- PC
  - Using a commissioning software (SoMove, SoMachine...), to configure and monitor the drive
  - To access the drive webserver
- SCADA system
- PLC system
- Graphic Display terminal, using Modbus protocol
- Modbus fieldbus

Connection is also possible using optional:

- Bluetooth
- Wi-Fi dongle
- USB/Modbus converter

**NOTE:**

- Verify that RJ45 cable is not damaged prior to connect it to the product otherwise the power supply of the control could be lost.
- Do not plug Ethernet or Sercos III cable in Modbus plug or vice versa.
- Do not plug PTI, PTO interface cable to Ethernet, Sercos III or Modbus plugs or vice versa.
- Use different cable colors for Ethernet, Sercos III, Modbus, PTI or PTO to facilitate Fast Device Replacing operations.
- Verify the correct wiring of the drive before to switch the system on.

# Control Terminals Electrical Data for Frame Sizes 1...3

## Preliminary Steps

### **DANGER**

#### **HAZARD OF ELECTRIC SHOCK, EXPLOSION OR ARC FLASH**

Read and understand the instructions in **Product Related Information** chapter before performing any procedure in this chapter.

**Failure to follow these instructions will result in death or serious injury.**

### **NOTICE**

#### **INCORRECT VOLTAGE**

Supply the digital inputs with 24 Vdc only.

**Failure to follow these instructions can result in equipment damage.**

## General

This section provides technical data relating to control terminals on frame sizes 1...3. The control terminals electrical data are different for frame sizes 1,2,3 and frame sizes 4 and 5, page 142.

#### **NOTE:**

- For a description of the terminal arrangement, refer to Arrangement and Characteristics of Control Terminals and Communication And I/O Ports, page 125.
- For cable lengths, refer to the table given in the Cable Length Instructions For the Control Part section, page 90.
- For factory setting I/O assignment, refer to the programming manual.
- For all LEDs description, refer to the Drive status LEDs, page 153 or to the programming manual available on [www.se.com](http://www.se.com).

## Drive Frame Sizes 1...3 - Top Side CN2 Connector

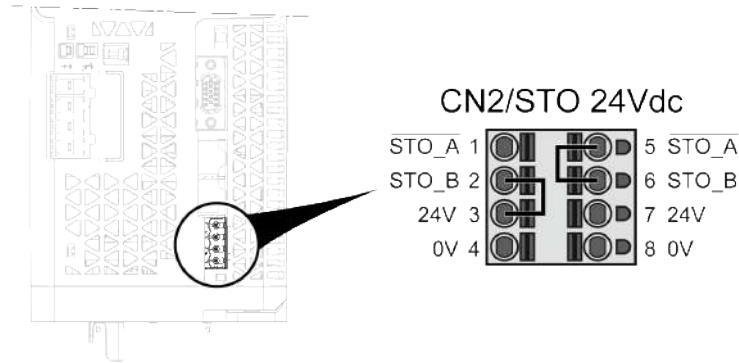

Alternative connection: wiring from drive to drive

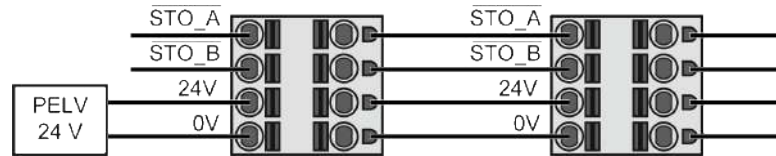

Terminal	Description	I/O Type	Electrical characteristics
STO_A, STO_B	STO inputs, SIL3	I	<b>Safety Function STO Inputs</b> Refer to the Embedded Safety Function Manual (NVE64143) available on <a href="http://www.se.com">www.se.com</a>
24V	Output: power supply for digital inputs and safety function STO inputs  Input: external 24 V supply of control	I/O	<ul style="list-style-type: none"> <li>Current maximum input: 1 A</li> <li>+24 Vdc</li> <li>Tolerance: minimum 20.4 Vdc, maximum 27 Vdc</li> <li>Current: maximum output: 200 mA</li> <li>Terminal protected against overload and short-circuit</li> <li>24V output can be disabled by menu <b>[24 V Supply Output] 5 2 4 V</b> to avoid possible 24 Vdc bus supply of other loads. By default 24 Vdc supply enabled. The external +24 Vdc controller supply must meet the requirements of IEC 61131-2 (PELV standard power supply unit).</li> </ul>
0V	Reference for 24 V supply		

## Drive Frame Sizes 1...3 - Top Side CN3 Connector

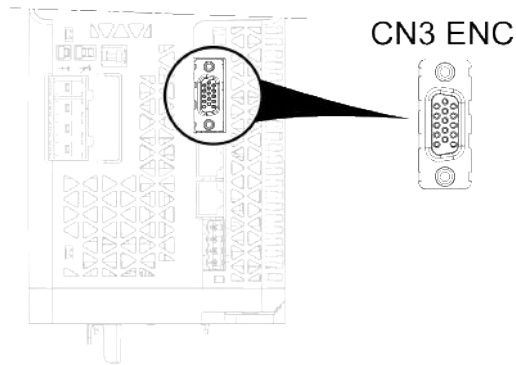

Terminal	Description	I/O Type	Electrical characteristics
ENC	Embedded Encoder	I/O	SUB-HD-15 female <ul style="list-style-type: none"> <li>• Digital encoder 5V RS422 A/B/I</li> <li>• Analog encoder 1Vpp sin/cos</li> </ul> Encoder supply: <ul style="list-style-type: none"> <li>• +5 V (max. 10 m), 250 mA</li> <li>• +12 V, 100 mA</li> <li>• +24 V, 100 mA</li> <li>• Thermal sensor input PTx</li> </ul>

**Connector type:** The encoder interface is realized with a female high density 15-pin Sub-HD connector. Screw lock thread 4-40 UNC

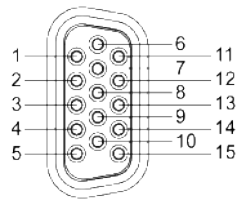

**Pin signal, function and electrical characteristics**

Pin	Signal name	Function/Meaning	Electrical Characteristics
1	DATA_A+	Data channel A	RS422/RS485, Rin 121 Ohm, 1 Mbit max.
2	DATA_A-		
3	ENC+24V_OUT	Encoder Supply 24 Vdc	+24 Vdc / 100mA
4	DATA_I+	Data channel I	RS422/RS485, Rin 121Ohm, 1 MBit max.
5	DATA_I-		
6	SIN	Sine analog input	1 Vpp, 100 kHz max.
7	ENC+12V_OUT	Encoder Supply 12 Vdc	+12 Vdc / 100mA
8	ENC_0V	Reference potential for encoder supply or Reference for Temperature sense	-
9	TEMP_SENSE	Temperature sensor input	Supported sensor: PTC, PT100, PT1000, KTY84, bimetal switch
10	DATA_B+	Data channel B	RS422/RS485, Rin 121 Ohm, 1 Mbit max.
11	DATA_B-		
12	COS	Cosinus analog input	1Vpp, 100 kHz max.
13	REFCOS	Reference for Cosinus	1Vpp, 100 kHz max.
14	REFSIN	Reference for Sinus analog input	1Vpp, 100 kHz max.
15	ENC+5V_OUT	Encoder Supply 5 Vdc	+5 Vdc / 250 mA
Shield		Overall cable shielding for signal lines	The shield is connected in the connector via the housing.

**Cable characteristics**

Pin	Twisted Wire pair digital	Twisted Wire pair analog	ABI	sin/cos 1 Vpp	I/O
1	1	NC	R	-	I/O
2					
3	4a *	4a *	-	-	O
4	3	NC	R	-	I
5					
6	NC	2	-	R	O
7	4b *	4b *	-	-	O
8	4 or 5	4 or 5	R	R	
9	5	5	Opt.	Opt.	I
10	2	NC	R	-	I
11					
12	NC	3	-	R	-
13					
14	NC	2	-	R	O
15	4c *	4c *	-	-	O
Shield			R	R	
<p>*: Wired depending on selected supply voltage</p> <p><b>R:</b> Required</p> <p>-: Not required</p> <p><b>Opt.:</b> Optional</p>					

**Special Features:**

- Wire break detection on DATA\_A and DATA\_B channel
- Safety: SIL1 (SC SIL2)

**NOTE:**

- Cable connector needs to be screwed to CN3 Encoder interface and cable must be maintained on cabinet backplane and drive top
- If you add an option module, verify the wiring diagram which is different between the CN3 connector and the Analog Encoder module (VW3A3422), or the Digital Encoder module (VW3A3420).

**Cable connection tips:**

- Before connecting the encoder cable check carefully the wiring against above signal table and ensure that there are no short circuits between signals
- For 24V encoder supply activation see the parameter **[24 V Supply Output] 5 2 4 V** described in the programming manual.
- For good EMC performance and connection reliability under vibration ensure proper assembly of encoder connector to CN3 interface by UNC screw fixing
- Encoder cable needs to be maintained on top of drive (use cable tie fixation on plastic fin) or cabinet backplane for strain relief

Maximum cable length according to encoder supply:

- 12 Vdc / 24 Vdc: 100 m (328 ft)
- 5 Vdc: 10 m (32 ft)

Recommended encoder cable:

- Encoder cable 100 m (328 ft), ends open, catalog number VW3M8221R1000
  - 1 x 2 x 0.5 mm<sup>2</sup> (AWG20) for supply line
  - 5 x 2 x 0.25 mm<sup>2</sup> (AWG26) for signal and sensor lines

## Drive Frame Sizes 1...3 - Top Side CN4 Connector

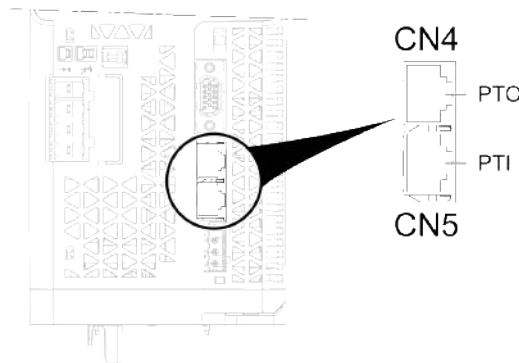

Terminal	Description	I/O Type	Electrical characteristics
PTO	Pulse train output	O	5 Vdc differential RS422 signals <ul style="list-style-type: none"> <li>• Logic level as per RS422</li> <li>• Output frequency per signal ≤ 500 kHz</li> <li>• Motor increments per second ≤ 1.6*10<sup>6</sup> Inc/s</li> </ul>

Recommended encoder cable:

- Both ends grounded
- Twisted Pair
- PELV
- Minimum conductor cross section: 0.14 mm<sup>2</sup> (AWG 24)
- Maximum length: 100m (328 ft)

## PTO, Detail of Connector Pin

RJ45 Pin	PTO Function		Twisted Pair (P)
1	A	Chanel A	(P1)
2	/A	Chanel A inverted	(P1)
3	I	Chanel I	(P3)
4	B	Chanel B	(P2)
5	/B	Chanel B inverted	(P2)
6	/I	Chanel I inverted	(P3)
7		0 Volt	–
8		0 Volt	–

## Drive Frame Sizes 1...3 - Top Side CN5 Connector

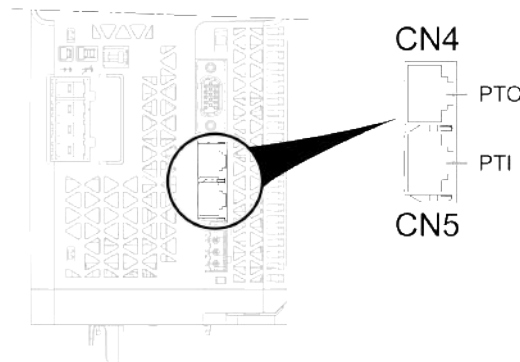

Terminal	Description	I/O Type	Electrical characteristics
PTI	Pulse train input	I	5 Vdc or 24 Vdc signals.  The following signals can be connected: <ul style="list-style-type: none"> <li>• A/B signals (Encoder channel A / Encoder channel B)</li> <li>• P/D signals (Pulse/Direction)</li> <li>• CW/CCW signals (ClockWise / CounterClockWise)</li> </ul>

Recommended encoder cable:

- Both ends grounded
- Twisted Pair
- PELV
- Minimum conductor cross section: 0.14 mm<sup>2</sup> (AWG 24)

### PTI, Input circuit and selection of method

The input circuit and the selected method affect the maximum permissible input frequency and the maximum permissible line length:

Input circuit	Unit	RS422	Push pull	Open collector
Minimum input frequency with method position synchronization	Hz	0	0	0
Minimum input frequency with method velocity synchronization	Hz	100	100	100
Maximum input frequency	MHz	1	0.2	0.01
Maximum line length	m (ft)	100 (328)	10 (32.8)	1 (3.28)

**PTI, signal Input circuits 5 Vdc**

RS422

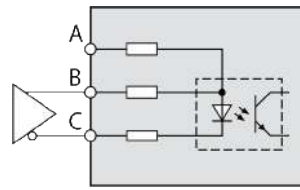

Push Pull

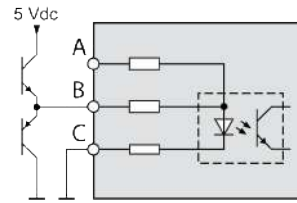

Open Collector

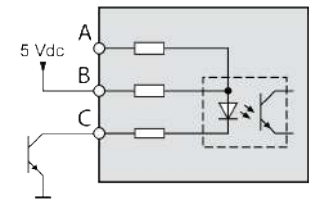

**PTI, signal Input circuits 24 Vdc**

Push Pull

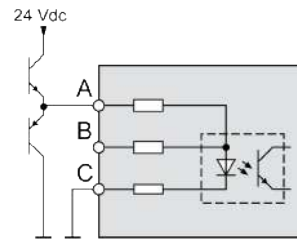

Open Collector

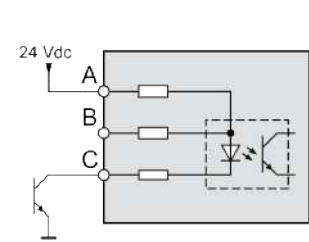

## PTI, Detail of Connector Pins

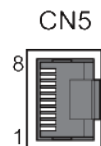

PTI signal	Pin	Input	RS422 or 5Vdc (1)		24Vdc	
			Twisted Pair (P)	Function	Twisted Pair (P)	Function
A/B	1	B	(P1)	Encoder channel A 5Vdc	-	-
	2	C	(P1)	Encoder channel A, inverted	(P1)	Encoder channel A, inverted
	3	-	-	-	-	-
	4	B	(P2)	Encoder channel B 5Vdc	-	-
	5	C	(P2)	Encoder channel B, inverted	(P2)	Encoder channel B, inverted
	6	-	-	-	-	-
	7	A	-	-	(P1)	Encoder channel A 24Vdc
	8	A	-	-	(P2)	Encoder channel B 24Vdc
P/D	1	B	(P1)	Pulse 5Vdc	-	-
	2	C	(P1)	Pulse, inverted	(P1)	Pulse, inverted
	3	-	-	-	-	-
	4	B	(P2)	Direction 5Vdc	-	-
	5	C	(P2)	Direction, inverted	(P2)	Direction, inverted
	6	-	-	-	-	-
	7	A	-	-	(P1)	Pulse 24Vdc
	8	A	-	-	(P2)	Direction 24Vdc
CW/CCW	1	B	(P1)	Pulse positive 5Vdc	-	-
	2	C	(P1)	Pulse positive, inverted	(P1)	Pulse positive, inverted
	3	-	-	-	-	-
	4	B	(P2)	Pulse negative 5Vdc	-	-
	5	C	(P2)	Pulse negative, inverted	(P2)	Pulse negative, inverted
	6	-	-	-	-	-
	7	A	-	-	(P1)	Pulse positive 24Vdc
	8	A	-	-	(P2)	Pulse negative 24Vdc

(1) Due to the input current of the optocoupler in the input circuit, a parallel connection of a driver output to several devices is not permitted.

# Drive Frame Sizes 1...3 - Front Side CN6 Connectors

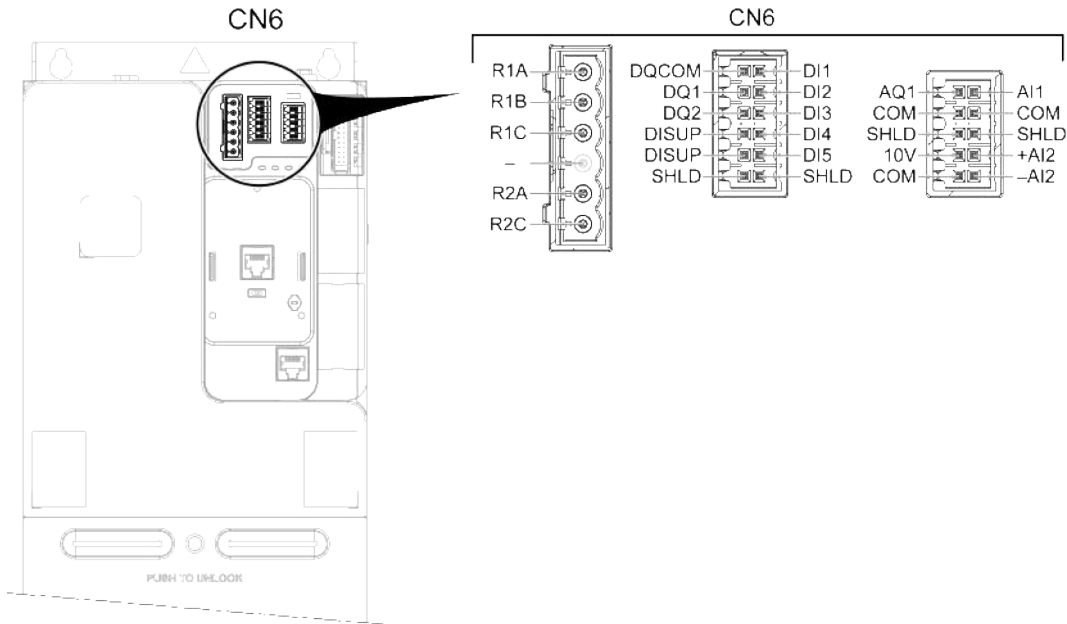

Terminal	Description	I/O Type	Electrical characteristics
R1A	NO contact of relay R1	O	<b>Output Relay R1</b> <ul style="list-style-type: none"> <li>Minimum switching capacity: 5 mA for 24 Vdc</li> <li>Maximum switching current on resistive load: 3 A for 250 Vac (OVC II) and 30 Vdc</li> <li>Maximum switching current on inductive load: (<math>\cos \phi \geq 0.4</math> and <math>L/R \leq 7</math> ms) 2 A for 250 Vac (OVC II) and 30 Vdc. Inductive load must be equipped with a voltage surge suppression device according to AC or DC operation with total energy dissipation greater than the inductive energy stored in the load. Refer to sections Output Relay with Inductive AC Loads, page 178 and Output Relay with Inductive DC Loads, page 179.</li> <li>Refresh time: 5 ms <math>\pm</math> 0.5 ms</li> <li>Service life: 100,000 operations at maximum switching current</li> </ul>
R1B	NC contact of relay R1	O	
R1C	Common point contact of relay R1	O	
-	Not wired	NC	Must not be wired to help ensure insulation distance with 230 Vac signals
R2A	NO contact of relay R2	O	<b>Output Relay R2</b> <ul style="list-style-type: none"> <li>Minimum switching capacity: 5 mA for 24 Vdc</li> <li>Maximum switching current on resistive load: 5 A for 250 Vac (OVCII) and 3A for 30 Vdc</li> <li>Maximum switching current on inductive load: (<math>\cos \phi \geq 0.4</math> and <math>L/R \leq 7</math> ms) 2 A for 250 Vac (OVCII) and 30 Vdc. Inductive load must be equipped with a voltage surge limitation device according to AC or DC operation with total energy dissipation greater than the inductive energy stored in the load. Refer to sections Output Relay with Inductive AC Loads, page 178 and Output Relay with Inductive DC Loads, page 179.</li> <li>Refresh time: 5 ms <math>\pm</math> 0.5 ms</li> <li>Service life:                             <ul style="list-style-type: none"> <li>100,000 operations at maximum switching current</li> <li>1,000,000 operations at 0.5 A</li> </ul> </li> </ul>
R2C	Common point contact of relay R2	O	
DQCOM	Digital output common	I/O	Common for Logic output DQx
DQ1	Digital input/output	I/O	2 programmable logic inputs/outputs, using configuration menus <b>[DQ1 Configuration]</b> $d \ o \ 1$ and <b>[DQ2 Configuration]</b> $d \ o \ 2$ <p>Digital Output</p> <ul style="list-style-type: none"> <li>Insulated, Input impedance 4.4 k<math>\Omega</math></li> <li>Maximum voltage: 30 Vdc</li> <li>Maximum output current: 100 mA</li> <li>Frequency range: 0...1 kHz</li> <li>Output Positive/Negative logic is managed by user external wiring.</li> </ul>
DQ2			

Terminal	Description	I/O Type	Electrical characteristics
			Digital Input: Inputs comply with IEC/EN 61131-2 logic type 1 <ul style="list-style-type: none"> <li>• Positive logic (Source): State 0 if <math>\leq 5</math> Vdc or logic input not wired, state 1 if <math>\geq 11</math> Vdc</li> <li>• Negative logic (Sink): State 0 if <math>\geq 16</math> Vdc or logic input not wired, state 1 if <math>\leq 10</math> Vdc</li> <li>• Maximum sampling time: 2 ms + 0.5 ms maximum</li> </ul> Multiple assignment makes it possible to configure several functions on one input
DISUP	Digital input supply	I/O	Common supply for digital inputs on front potential depending on Sink/Source switch setting.
SHLD	I/O Shield	I/O	Shield for inputs/outputs
DI1-DI5	Digital input	I	5 programmable logic inputs. 24 Vdc input voltage Comply with IEC/EN 61131-2 logic type 1 <ul style="list-style-type: none"> <li>• Positive logic (Source): State 0 if <math>\leq 5</math> Vdc or logic input not wired, state 1 if <math>\geq 11</math> Vdc</li> <li>• Negative logic (Sink): State 0 if <math>\geq 16</math> Vdc or logic input not wired, state 1 if <math>\leq 10</math> Vdc</li> <li>• Impedance 4.4 k<math>\Omega</math></li> <li>• Maximum voltage: 30 Vdc</li> <li>• Sampling time: 2 ms + 0.5 ms maximum</li> </ul> Multiple assignment makes it possible to configure several functions on one input (example: DI1 assigned to forward and preset speed 2, DI3 assigned to reverse and preset speed 3).
AQ1	Analog output	O	Analog output software-configurable for voltage or current <ul style="list-style-type: none"> <li>• Voltage analog output 0...10 Vdc, minimum. Minimum load impedance 470 <math>\Omega</math></li> <li>• Current analog output X-Y mA by programming X and Y from 0...20 mA, maximum load impedance 500 <math>\Omega</math></li> <li>• Sampling time: 5 ms + 1 ms maximum</li> <li>• Resolution 10 bits</li> <li>• Accuracy: <math>\pm 1</math> % for a temperature variation of 60 °C (108 °F)</li> <li>• Linearity <math>\pm 0.2</math> %</li> </ul>
AI1	Analog input and sensor input	I	Software-configurable V/A: voltage or current analog input <ul style="list-style-type: none"> <li>• Voltage analog input 0...10 Vdc, impedance 30 k<math>\Omega</math>,</li> <li>• Current analog input X-Y mA by programming X and Y from 0...20 mA, with impedance 250 <math>\Omega</math></li> <li>• Sampling time: 1 ms + 1 ms maximum</li> <li>• Resolution 12 bits</li> <li>• Accuracy: <math>\pm 0.6</math> % for a temperature variation of 60 °C (108 °F)</li> <li>• Linearity <math>\pm 0.15</math> % of maximum value</li> </ul> Software-configurable thermal sensors <ul style="list-style-type: none"> <li>• <b>PT100</b> <ul style="list-style-type: none"> <li>◦ 1 thermal sensor</li> <li>◦ Sensor current: 5 mA maximum</li> <li>◦ Range -20...200 °C (-4...392 °F)</li> <li>◦ Accuracy <math>\pm 4</math> °C (<math>\pm 7.2</math> °F) for a temperature variation of 60 °C (108 °F)</li> </ul> </li> <li>• <b>PT1000</b> <ul style="list-style-type: none"> <li>◦ 1 thermal sensor</li> <li>◦ Sensor current: 1 mA</li> <li>◦ Range -20...200 °C (-4...392 °F)</li> <li>◦ Accuracy <math>\pm 4</math> °C (<math>\pm 7.2</math> °F) for a temperature variation of 60 °C (108 °F)</li> </ul> </li> <li>• <b>KTY84</b> <ul style="list-style-type: none"> <li>◦ 1 thermal sensor</li> <li>◦ Sensor current: 1 mA</li> <li>◦ Range -20...200 °C (-4...392 °F)</li> <li>◦ Accuracy <math>\pm 4</math> °C (<math>\pm 7.2</math> °F) for a temperature variation of 60 °C (108 °F)</li> </ul> </li> </ul>

Terminal	Description	I/O Type	Electrical characteristics
			<ul style="list-style-type: none"> <li>• <b>PTC</b> <ul style="list-style-type: none"> <li>◦ 6 sensors maximum mounted in series</li> <li>◦ Sensor current: 1 mA</li> <li>◦ Nominal value: &lt; 1.5 k<math>\Omega</math></li> <li>◦ Overheat trigger threshold: 2.9 k<math>\Omega</math> <math>\pm</math> 0.2 k<math>\Omega</math></li> <li>◦ Overheat reset threshold: 1.575 k<math>\Omega</math> <math>\pm</math> 0.075 k<math>\Omega</math></li> <li>◦ Low impedance detection threshold: 50 <math>\Omega</math> –10 <math>\Omega</math>/+20 <math>\Omega</math></li> <li>◦ Protected for low impedance &lt; 1000 <math>\Omega</math></li> </ul> </li> </ul>
AI4-AI5	Analog input and sensor input	I	<p><b>NOTE:</b> AI4 and AI5 are available only if VW3A3203 I/O extension module has been inserted.</p> <p>You can order the I/O extension module on <a href="http://www.se.com/ww/en/product/VW3A3203">www.se.com/ww/en/product/VW3A3203</a>.</p> <p>For the characteristics, refers to the instruction sheet (EAV76404).</p>
COM	Analog I/O Common	I/O	0 V for analog outputs and inputs
SHLD	Analog I/O Shield	I/O	Shield for analog inputs/outputs
10V	Output supply for Analog input / Ref. pot.	O	<p>Internal supply for the analog inputs</p> <ul style="list-style-type: none"> <li>• 10.5 Vdc</li> <li>• Tolerance <math>\pm</math>5 %</li> <li>• Current: maximum 10 mA</li> <li>• Short circuit protected</li> </ul>
AI2+/AI2-	Analog input differential	I	<p>Voltage bipolar analog input –10...10 Vdc, impedance 20 k<math>\Omega</math></p> <ul style="list-style-type: none"> <li>• Maximum sampling time: 1 ms + 1 ms maximum</li> <li>• Resolution 12 bits</li> <li>• Accuracy: <math>\pm</math>0.6 % for a temperature variation of 60 <math>^{\circ}</math>C (108 <math>^{\circ}</math>F)</li> <li>• Linearity <math>\pm</math>0.15 % of maximum value</li> </ul>

## Drive Frame Sizes 1...3 - Front Side HMI and CN7 RJ45 Modbus Connectors

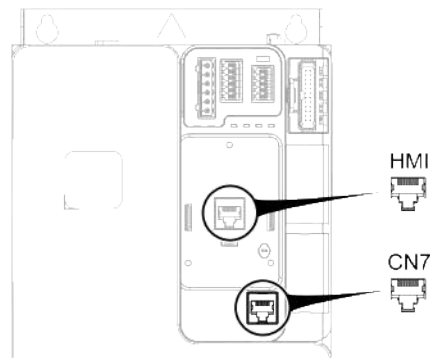

**HMI:** It is intended to connect the optional plain text display terminal or graphic display terminal.

- Plain text display terminal (VW3A1113): can be either plugged on the drive or mounted on the door of an enclosure with its dedicated door mounting kit (VW3A1114).
- Graphic display terminal (VW3A1111): cannot be plugged directly on the drive. It can be connected to the HMI port using a cable or it can be mounted on the door of an enclosure with its dedicated door mounting kit (VW3A1112)

**CN7:** RJ45 Modbus VP12S port reserved for modbus fieldbus and commissioning tool.

Wiring Diagram - PC with commissioning software



Detail of connector pins

Pin	Signal	Meaning	I/O
1...3	-	Reserved	-
4	MOD_D1	Bidirectional transmit/receive signal	RS485 level
5	MOD_D0	Bidirectional transmit/receive signal, inverted	RS485 level
6	-	Reserved	-
7	MOD+10V_OUT	10 V supply, maximum 100 mA	O
8	MOD_0V	Reference potential to MOD+10V_OUT	

# Control Terminals Electrical data for Frame Sizes 4 and 5

## General

This section provides technical data relating to control terminals for frame sizes 4, 5. The control terminals electrical data are different for frame sizes 1,2,3 and frame sizes 4, 5.

**NOTE:**

- For a description of the terminal arrangement, refer to Arrangement and Characteristics of Control Terminals and Communication And I/O Ports, page 125.
- For cable lengths, refer to the table given in the Cable Length Instructions For the Control Part section, page 90.
- For factory setting I/O assignment, refer to the programming manual.
- For all LEDs description, refer to the Drive status LEDs, page 153 or to the programming manual.

## Characteristics of Control Terminals



**NOTE:**

- For a description of the terminal arrangement, refer to Arrangement and Characteristics of Control Terminals and Communication And I/O Ports, page 125.
- For factory setting I/O assignment, refer to the programming manual.

Terminal	Description	I/O Type	Electrical characteristics
R1A	NO contact of relay R1	O	<b>Output Relay R1</b> <ul style="list-style-type: none"> <li>• Minimum switching capacity: 5 mA for 24 Vdc</li> <li>• Maximum switching current on resistive load: 3 A for 250 Vac (OVC II) and 30 Vdc</li> <li>• Maximum switching current on inductive load: (cos <math>\phi \geq 0.4</math> and <math>L/R \leq 7</math> ms) 2 A for 250 Vac (OVC II) and 30 Vdc. Inductive load must be equipped with a voltage surge suppression device according to AC or DC operation with total energy dissipation greater than the inductive energy stored in the load. Refer to sections Output Relay with Inductive AC Loads, page 178 and Output Relay with Inductive DC Loads, page 179.</li> <li>• Refresh time: 5 ms <math>\pm</math> 0.5 ms</li> <li>• Service life: 100,000 operations at maximum switching current</li> </ul>
R1B	NC contact of relay R1	O	
R1C	Common point contact of relay R1	O	
R2A	NO contact of relay R2	O	<b>Output Relay R2/R3</b>

Terminal	Description	I/O Type	Electrical characteristics
R2C	Common point contact of relay R2	O	<ul style="list-style-type: none"> <li>Minimum switching capacity: 5 mA for 24 Vdc</li> <li>Maximum switching current on resistive load: 5 A for 250 Vac (OVCII) and 3A for 30 Vdc</li> <li>Maximum switching current on inductive load: (<math>\cos \phi \geq 0.4</math> and <math>L/R \leq 7</math> ms) 2 A for 250 Vac (OVCII) and 30 Vdc. Inductive load must be equipped with a voltage surge limitation device according to AC or DC operation with total energy dissipation greater than the inductive energy stored in the load. Refer to sections Output Relay with Inductive AC Loads, page 178 and Output Relay with Inductive DC Loads, page 179.</li> <li>Refresh time: 5 ms <math>\pm</math> 0.5 ms</li> <li>Service life: <ul style="list-style-type: none"> <li>100,000 operations at maximum switching current</li> <li>1,000,000 operations at 0.5 A</li> </ul> </li> </ul>
R3A	NO contact of relay R3	O	
R3C	Common point contact of relay R3	O	
<u>STOA</u> , STOB	STO inputs	I	<b>Safety Function STO Inputs</b> Refer to the Embedded Safety Function Manual (NVE64143) available on <a href="http://www.se.com">www.se.com</a>
24V	Output power supply for digital inputs and safety function STO inputs	O	Use only PELV standard power supply unit. <ul style="list-style-type: none"> <li>+24 Vdc</li> <li>Tolerance: minimum 20.4 Vdc, maximum 27 Vdc</li> <li>Current: maximum 200 mA for both 24 Vdc terminals</li> <li>Terminal protected against overload and short-circuit</li> <li>In Sink Ext position, this supply is powered by external PLC supply</li> </ul>
10V	Output supply for Analog input	O	Internal supply for the analog inputs <ul style="list-style-type: none"> <li>10.5 Vdc</li> <li>Tolerance <math>\pm 5</math> %</li> <li>Current: maximum 10 mA</li> <li>Short circuit protected</li> </ul>
AI1, AI3	Analog input and sensor input	I	Software-configurable V/A : voltage or current analog input <ul style="list-style-type: none"> <li>Voltage analog input 0...10 Vdc, impedance 31.5 k<math>\Omega</math>,</li> <li>Current analog input X-Y mA by programming X and Y from 0...20 mA, with impedance 250 <math>\Omega</math></li> <li>Sampling time: 1 ms + 1 ms maximum</li> <li>Resolution 12 bits</li> <li>Accuracy: <math>\pm 0.6</math> % for a temperature variation of 60 °C (108 °F)</li> <li>Linearity <math>\pm 0.15</math> % of maximum value</li> </ul> Software-configurable thermal sensors <ul style="list-style-type: none"> <li><b>PT100</b> <ul style="list-style-type: none"> <li>1 thermal sensor</li> <li>Sensor current: 5 mA maximum</li> <li>Range -20...200 °C (-4...392 °F)</li> <li>Accuracy <math>\pm 4</math> °C (<math>\pm 7.2</math> °F) for a temperature variation of 60 °C (108 °F)</li> </ul> </li> <li><b>PT1000</b> <ul style="list-style-type: none"> <li>1 thermal sensor</li> <li>Sensor current: 1 mA</li> <li>Range -20...200 °C (-4...392 °F)</li> <li>Accuracy <math>\pm 4</math> °C (<math>\pm 7.2</math> °F) for a temperature variation of 60 °C (108 °F)</li> </ul> </li> <li><b>KTY84</b> <ul style="list-style-type: none"> <li>1 thermal sensor</li> <li>Sensor current: 1 mA</li> <li>Range -20...200 °C (-4...392 °F)</li> <li>Accuracy <math>\pm 4</math> °C (<math>\pm 7.2</math> °F) for a temperature variation of 60 °C (108 °F)</li> </ul> </li> </ul>

Terminal	Description	I/O Type	Electrical characteristics
			<ul style="list-style-type: none"> <li>• <b>PTC</b> <ul style="list-style-type: none"> <li>◦ 6 sensors maximum mounted in series</li> <li>◦ Sensor current: 1 mA</li> <li>◦ Nominal value: &lt; 1.5 k<math>\Omega</math></li> <li>◦ Overheat trigger threshold: 2.9 k<math>\Omega</math> <math>\pm</math> 0.2 k<math>\Omega</math></li> <li>◦ Overheat reset threshold: 1.575 k<math>\Omega</math> <math>\pm</math> 0.075 k<math>\Omega</math></li> <li>◦ Low impedance detection threshold: 50 <math>\Omega</math> –10 <math>\Omega</math>/+20 <math>\Omega</math></li> <li>◦ Protected for low impedance &lt; 1000 <math>\Omega</math></li> </ul> </li> </ul>
AI4-AI5	Analog input and sensor input	I	<p><b>NOTE:</b> AI4 and AI5 are available only if VW3A3203 I/O extension module has been inserted.</p> <p>You can order the I/O extension module on <a href="http://www.se.com/ww/en/product/VW3A3203">www.se.com/ww/en/product/VW3A3203</a>.</p> <p>For the characteristics, refers to the instruction sheet (EAV76404).</p>
COM	Analog I/O common	I/O	0 V for Analog inputs/outputs
AI2	Analog input	I	<p>Voltage bipolar analog input –10...10 Vdc, impedance 31.5 k<math>\Omega</math></p> <ul style="list-style-type: none"> <li>• Sampling time: 1 ms + 1 ms maximum</li> <li>• Resolution 12 bits</li> <li>• Accuracy: <math>\pm</math>0.6 % for a temperature variation of 60 <math>^{\circ}</math>C (108 <math>^{\circ}</math>F)</li> <li>• Linearity <math>\pm</math>0.15 % of maximum value</li> </ul>
AQ1	Analog output	O	<p>AQ: Analog output software-configurable for voltage or current</p> <ul style="list-style-type: none"> <li>• Voltage analog output 0...10 Vdc, minimum. Minimum load impedance 470 <math>\Omega</math>,</li> <li>• Current analog output X-Y mA by programming X and Y from 0...20 mA, maximum load impedance 500 <math>\Omega</math></li> <li>• Sampling time: 5 ms + 1 ms maximum</li> <li>• Resolution 10 bits</li> <li>• Accuracy: <math>\pm</math>1 % for a temperature variation of 60 <math>^{\circ}</math>C (108 <math>^{\circ}</math>F)</li> <li>• Linearity <math>\pm</math>0.2 %</li> </ul>
AQ2	Analog output	O	
COM	Digital and analog output Common	I/O	0 V for analog outputs and logic output
DQ–	Digital output DQ1	O	<p>Digital output configurable by switch</p> <ul style="list-style-type: none"> <li>• Insulated</li> <li>• Maximum voltage: 30 Vdc</li> <li>• Maximum current: 100 mA</li> <li>• Frequency range: 0...1 kHz</li> <li>• Positive/Negative logic is managed by user external wiring.</li> </ul>
DQ+		O	
DQ+	Pulse output	O	<p>Pulse train output configurable by switch</p> <ul style="list-style-type: none"> <li>• Open collector not insulated</li> <li>• Maximum voltage: 30 Vdc</li> <li>• Maximum current: 20 mA</li> <li>• Frequency range: 0...30 kHz</li> </ul>
P24	External input supply	I	<p>+24 Vdc external input supply</p> <ul style="list-style-type: none"> <li>• Tolerance: minimum 19 Vdc, maximum 30 Vdc</li> <li>• Maximum current: 0.8 A</li> </ul>
0V	0 V	I/O	0 V of P24

Terminal	Description	I/O Type	Electrical characteristics
DI1-DI8	Digital inputs	I	<p>8 programmable logic inputs 24 Vdc, comply with IEC/EN 61131-2 logic type 1</p> <ul style="list-style-type: none"> <li>• Positive logic (Source): State 0 if <math>\leq 5</math> Vdc or logic input not wired, state 1 if <math>\geq 11</math> Vdc</li> <li>• Negative logic (Sink): State 0 if <math>\geq 16</math> Vdc or logic input not wired, state 1 if <math>\leq 10</math> Vdc</li> <li>• Impedance 3.5 k<math>\Omega</math></li> <li>• Maximum voltage: 30 Vdc</li> <li>• Sampling time: 2 ms + 0.5 ms maximum</li> </ul> <p>Multiple assignment makes it possible to configure several functions on one input (example: DI1 assigned to forward and preset speed 2, DI3 assigned to reverse and preset speed 3).</p>
DI7-DI8	Pulse inputs	I	<p>Programmable Pulse input, comply with level 1 PLC, IEC 65A-68 standard</p> <ul style="list-style-type: none"> <li>• State 0 if <math>&lt; 0.6</math> Vdc, state 1 if <math>&gt; 2.5</math> Vdc</li> <li>• Pulse counter 0...30 kHz</li> <li>• Frequency range: 0...30 kHz</li> <li>• Cyclic ratio: 50 % <math>\pm</math> 10 %</li> <li>• Maximum input voltage 30 Vdc, <math>&lt; 10</math> mA</li> <li>• Sampling time: 5 ms + 1 ms maximum</li> </ul>

# Wiring The Control Part of Frame Sizes 4 and 5

## Preliminary Instructions

### **DANGER**

#### **HAZARD OF ELECTRIC SHOCK, EXPLOSION OR ARC FLASH**

Read and understand the instructions in **Product Related Information** chapter before performing any procedure in this chapter.

**Failure to follow these instructions will result in death or serious injury.**

### **NOTICE**

#### **INCORRECT VOLTAGE**

Supply the digital inputs with 24 Vdc only.

**Failure to follow these instructions can result in equipment damage.**

#### **NOTE:**

- Analog inputs and outputs AIx, AQx, COM use shielded cable and each analog input and output has its own COM line.
- Each PTC input has its own COM line, not shared with other Inputs/Outputs.
- All digital inputs DIx use one common 24V line in source mode or one common COM line in sink mode. This 24V or COM line is used only for DIx.
- Digital output DQ+/DQ- uses a 24V or a COM line which is not shared with other Inputs/Outputs.
- Safe torque off inputs  $\overline{\text{STOA}}$  /  $\overline{\text{STOB}}$  use shielded cables and one common 24V line. This 24V line is used only for  $\overline{\text{STOA}}$  /  $\overline{\text{STOB}}$ .

**NOTE:** For cable lengths, refer to the table given in the Cable Length Instructions For the Control Part section, page 90.

## Optional Module Installation and Wiring

### NOTE:

- For possible fieldbus module list, refer to the catalog.
- For fieldbus modules information, refer to the instruction sheet S1A45591 available on [www.se.com](http://www.se.com)

To help ensure correct wiring of the control part, apply the following instructions to install and connect a module to be wired

Step	Action
1	Insert the module in the slot A or B , page 128.
2	Insert the cable in the cabling plate, according to the outlined locations. The breakable cut out is used for fieldbus cables.
3	Connect the cable to the module

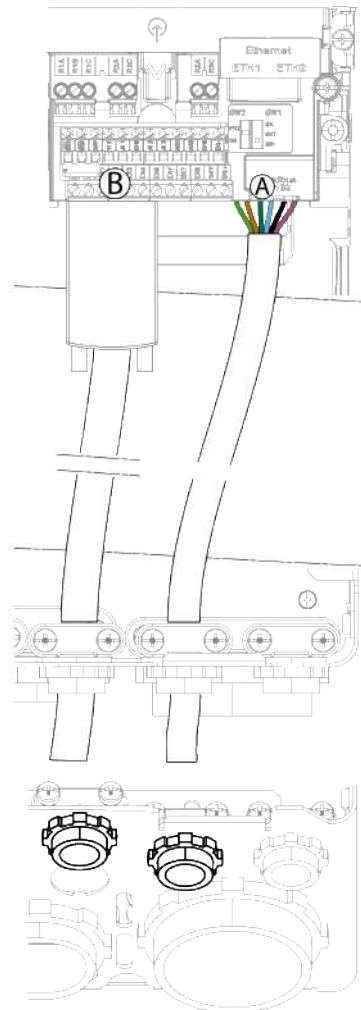

## I/O Relay Module Installation and Wiring

To help ensure correct wiring of the control part, apply the following instructions to install and connect an I/O relay module.

Step	Action
1	Insert the I/O relay module in an option slot.
2	Push the module into its location and keep access to the module terminal screws.
3	Insert the I/O cable in the cabling plate, according to the outlined location.
4	Wire the I/O relay module.
5	Push again the module to its final position.

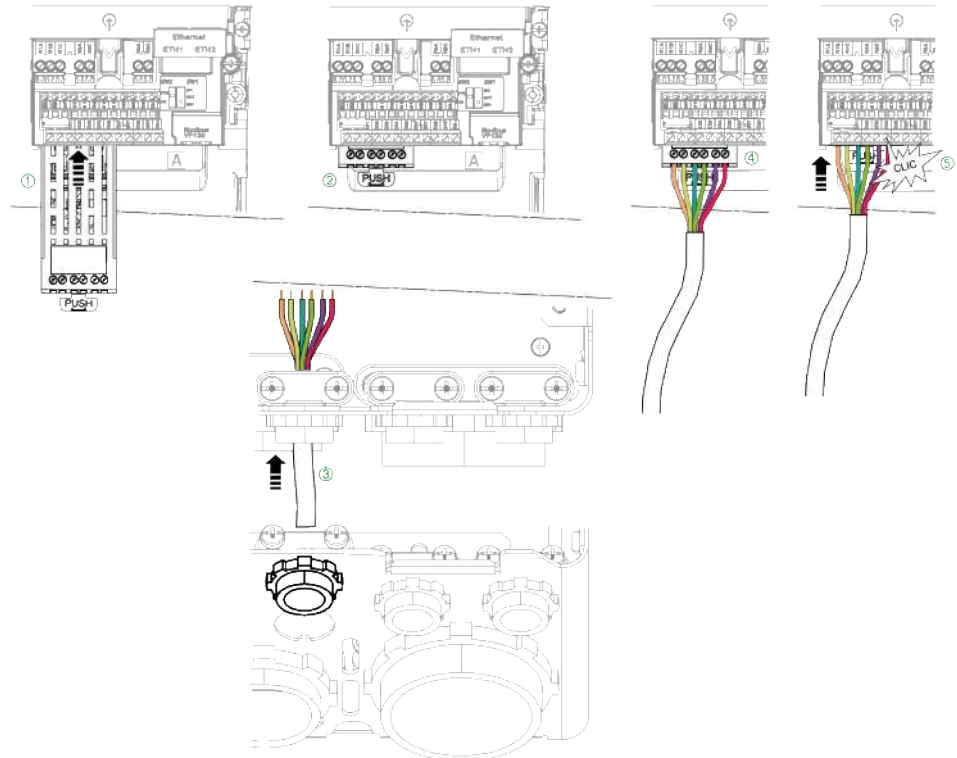

## Encoder Interface Module Installation and Wiring

To help ensure correct wiring of the control part, apply the following instructions to install the encoder interface module

Step	Action
1	Insert the encoder interface module in the slot B , page 128 and push it to its final position until you hear a “click” sound
2	Insert the cable in the cabling plate, according to the outlined location.
3	Wire the SUB-D connector
4	Plug the SUB-D connector on the option module

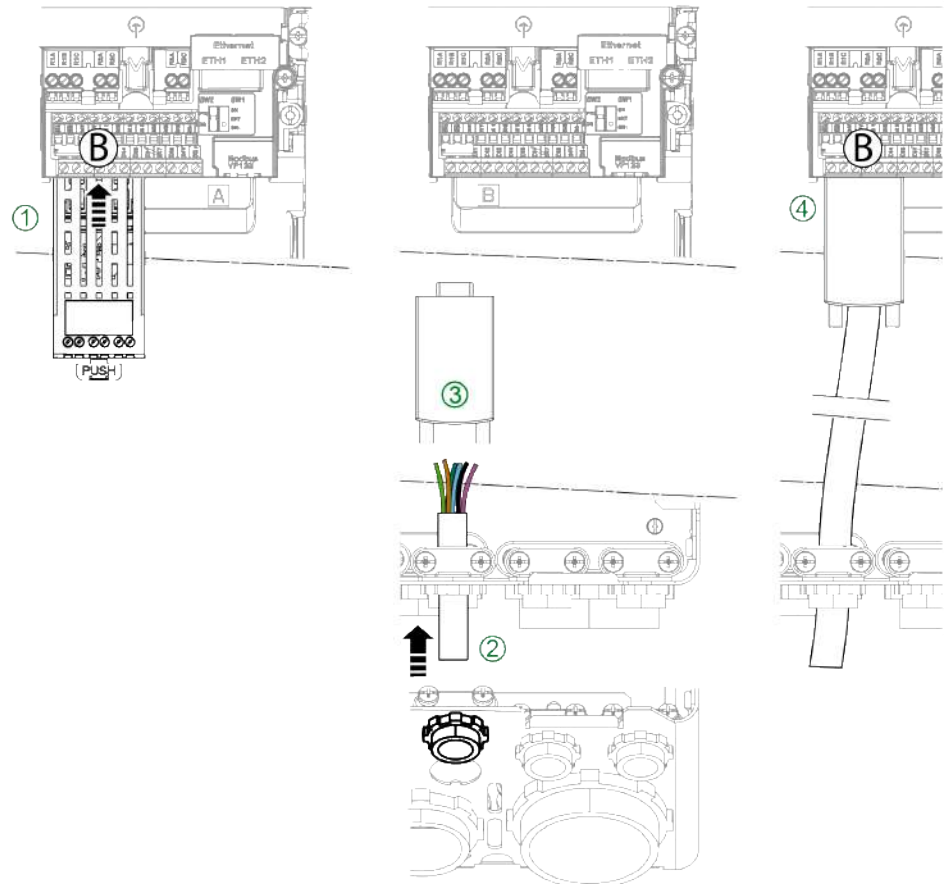

## Encoder Cable Shielding

To improve EMC performance:

- Connect the shielding to the encoder on the motor side.
- Ensure the shielding continuity of the cable between the drive and the encoder.
- On the drive side, perform the wiring of the optional digital encoder interface module as described on the figure below:

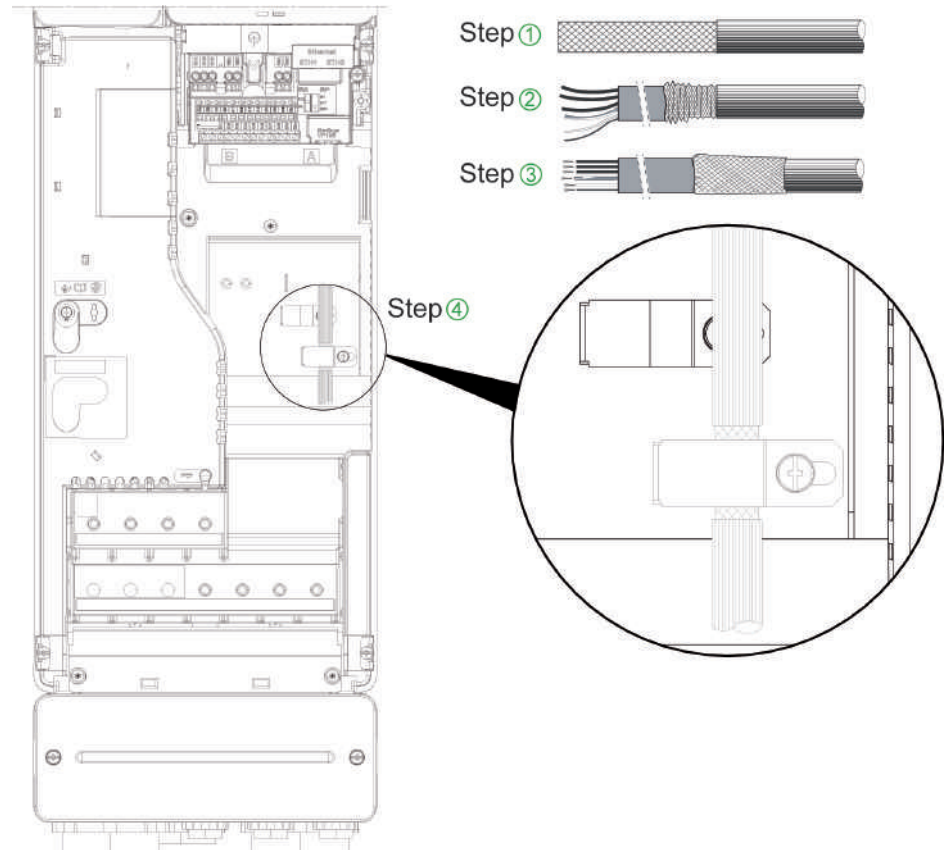

## Control Block Wiring

To help ensure correct wiring of the control part, apply the following instructions to wire the control block terminals

Step	Action
1	Wire the P24, 0V, the digital inputs (DI1...DI8), the 24V and DQ+ terminals
2	Wire the safety outputs $\overline{\text{STOA}}$ , $\overline{\text{STOB}}$ , the 24V, the 10V, the analog inputs (AI1...AI3), the COM, the analog outputs (AQ1...AQ2), the COM and DQ- terminals
3	Wire the Relay outputs

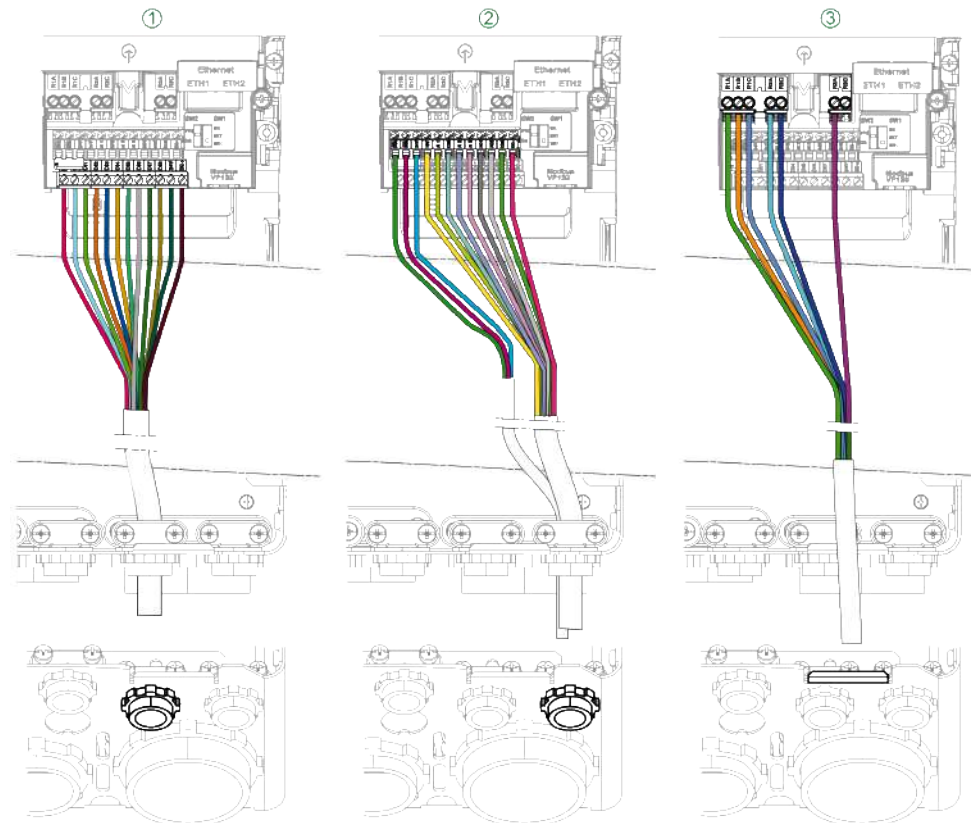

## Ethernet Cable Path

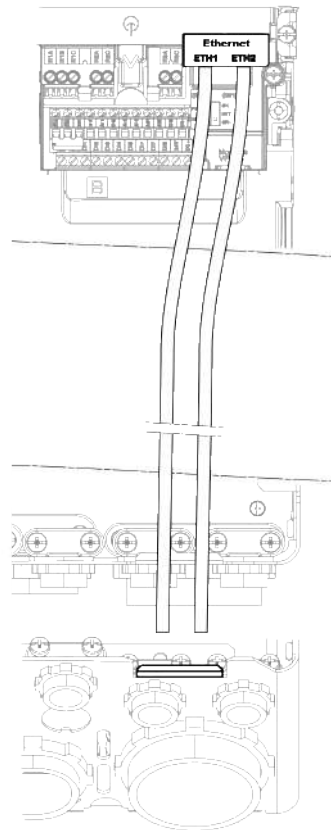

## Product LEDs

### Introduction

The drive embeds status LEDs that are used to indicate the drive status.

The number of LEDs available varies according to the drive rating.

- For frame sizes 1...3 - ATV340U07N4...ATV340D22N4: 4 LEDs.
- For frame sizes 1...3 - ATV340U07N4E...ATV340D22N4E: 4 additional LEDs on ETH1 and ETH2 ports.
- For frame sizes 4 and 5 - ATV340D30N4E to ATV340D75N4E: 10 LEDs.

### LEDs Description ATV340U07N4• to ATV340D22N4•

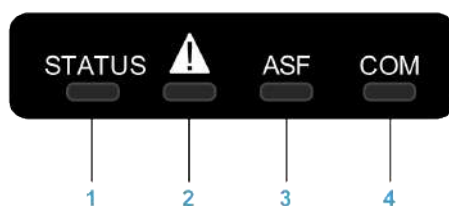

Following table provides the details of the drive status LEDs:

Item	LED	Color & status	Description
1	<b>STATUS</b>	OFF	Indicates that the drive is powered off
		Green flashing	Indicates that the drive is not running, ready to start
		Green blinking	Indicates that the drive is in transitory status (acceleration, deceleration, and so on)
		Green on	Indicates that the drive is running
		Yellow on	Device visual identification when using the DTM based commissioning software
2	<b>Warning/Error</b>	Red flashing	Indicates that the drive has detected a warning
		Red on	Indicates that the drive has detected an error
3	<b>ASF</b>	Yellow on	Indicates that the safety function has been triggered
4	<b>COM</b>	Yellow flashing	Indicates embedded Modbus serial activity

## LEDs Description ATV340D30N4E to ATV340D75N4E

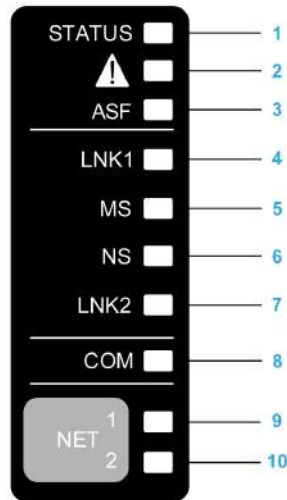

Following table provides the details of the drive status LEDs:

Item	LED	Color & status	Description
1	<b>STATUS</b>	OFF	Indicates that the drive is powered off
		Green flashing	Indicates that the drive is not running, ready to start
		Green blinking	Indicates that the drive is in transitory status (acceleration, deceleration, and so on)
		Green on	Indicates that the drive is running
		Yellow on	Device Visual identification function when using SoMove or the device DTM
2	<b>Warning/Error</b>	Red flashing	Indicates that the drive has detected a warning
		Red on	Indicates that the drive has detected an error
3	<b>ASF</b>	Yellow on	Indicates that the safety function has been triggered

Following table provides the details of the embedded Ethernet LEDs:

Item	LED	Color & status	Description
4	<b>LNK1</b>	OFF	No link.
		Green/Yellow flashing	Power on testing.
		Green on	Link established at 100 Mbit/s.
		Green flashing	Link established at 10 Mbit/s.
		Yellow flashing	Fieldbus activity at 100 Mbit/s.
		Yellow on	Fieldbus activity at 10 Mbit/s.
5	<b>MS</b>	OFF	No power is supplied to the device.
		Green/Red flashing	Power up testing.
		Green on	The device is operating correctly.
		Green flashing	The device has not been configured.
		Red flashing	The device has detected a recoverable minor detected error.
		Red on	The device has detected a non-recoverable major detected error.
6	<b>NS</b>	OFF	The device does not have an IP address or powered off.
		Green/Red flashing	Power on testing.
		Green on	A connection is established to control the command word.
		Green flashing	Device has a valid IP, but no command word connection.

Item	LED	Color & status	Description
		Red flashing	Duplicated IP.
		Red on	An established connection to control the command word is closes or timed out.
7	LNK2	OFF	No link.
		Green/Yellow flashing	Power on testing.
		Green on	Link established at 100 Mbit/s.
		Green flashing	Link established at 10 Mbit/s.
		Yellow flashing	Fieldbus activity at 100 Mbit/s.
		Yellow on	Fieldbus activity at 10 Mbit/s.

Following table provides the details of the embedded Modbus serial LEDs:

Item	LED	Color & status	Description
8	COM	Yellow flashing	Indicates embedded Modbus serial activity

Following table provides the details of the fieldbus module LEDs:

Item	LED	Color & status	Description
9	NET 1	Green/Red	For details, refer to the fieldbus manual
10	NET 2	Green/Red	For details, refer to the fieldbus manual

## Sercos III LEDs on ATV340.....S

Please refer to the ATV340 Sercos III manual PHA33735 (English).

## DC BUS LED on Frame Sizes 4 and 5

Frame Size 4

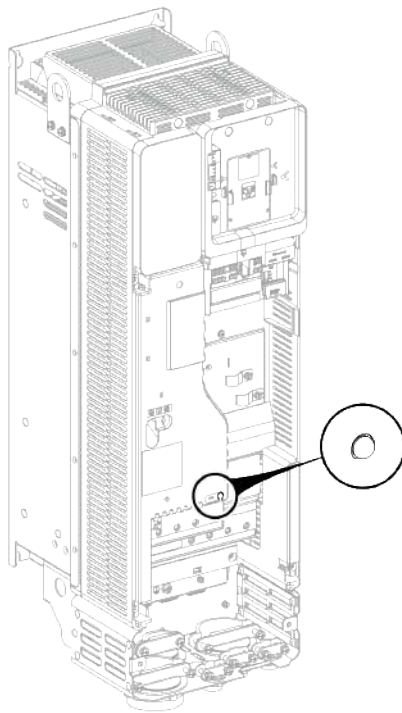

Frame Size 5

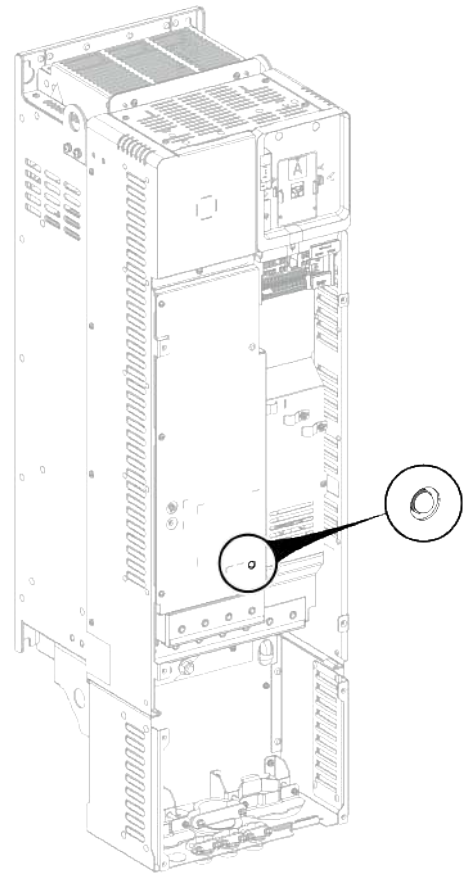

# SK EXT SRC Switch Configuration

## What's in This Chapter

SK-EXT-SRC Switch Configuration on Frame Sizes 1...3: ATV340U07N4•... D22N4• .....	158
SK-EXT-SRC Switch SW1 Configuration on Frame Sizes 4 and 5: ATV340D30N4E...D75N4E .....	159

## SK-EXT-SRC Switch Configuration on Frame Sizes 1...3: ATV340U07N4...D22N4•

### ⚠ WARNING

#### UNANTICIPATED EQUIPMENT OPERATION

- If the device is set to **SK** or **EXT**, do not connect the **0 V** terminal to ground or to protective ground.
- Verify that accidental grounding of digital inputs configured for sink logic, caused, for example, by damage to the signal cables, cannot occur.
- Follow all applicable standards and directives such as NFPA 79 and EN 60204 for proper control circuit grounding practices.

**Failure to follow these instructions can result in death, serious injury, or equipment damage.**

## Switch Description

The switch markings correspond to the following:

Marking	Description
SK	Sink internal
EXT	Sink external
SRC	Source

The switch is used to adapt the operation of the digital inputs to the technology of the programmable controller outputs. The switch is located below the HMI port. It has only an influence on DIx and DQx used in digital input mode.

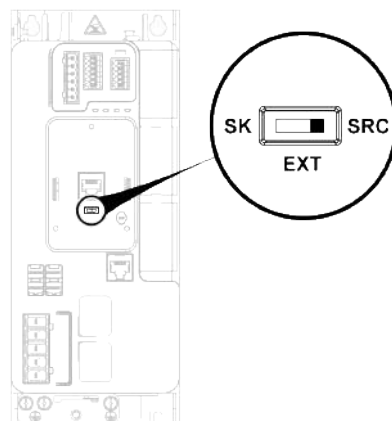

## Settings

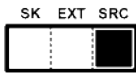
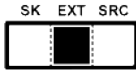
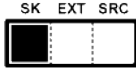
Switch Position	Description	Power Supply
	Source  Set the switch to SRC Source (factory setting) if using PLC outputs with PNP transistors.  Positive Logic PLC. Outputs switches to +24V when active. Common to Europe PLCs.	DISUP: 24 Vdc  Can be used to supply 24 Vdc to switches.
	External (sink)  Switch Set to EXT (Sink external) position and use of an External Power Supply	DISUP: To be connected to 24 Vdc to supply all DIx internal logic
	Sink  Set the switch to SK (Sink internal) if using PLC outputs with NPN transistors. Negative Logic PLC, Outputs switches to 0 V when active. Common to Asian PLCs.	DISUP: 0V  Can be used to supply 0V to switches

## SK-EXT-SRC Switch SW1 Configuration on Frame Sizes 4 and 5: ATV340D30N4E...D75N4E

### ⚠ WARNING

#### UNANTICIPATED EQUIPMENT OPERATION

- If the device is set to **SK** or **EXT**, do not connect the **0 V** terminal to ground or to protective ground.
- Verify that accidental grounding of digital inputs configured for sink logic, caused, for example, by damage to the signal cables, cannot occur.
- Follow all applicable standards and directives such as NFPA 79 and EN 60204 for proper control circuit grounding practices.

**Failure to follow these instructions can result in death, serious injury, or equipment damage.**

## Switch Description

The switch markings correspond to the following:

Marking	Description
SK	Sink internal
EXT	Sink external
SRC	Source

The switch is used to adapt the operation of the logic inputs to the technology of the programmable controller outputs. To access the switch, follow the Access to control Terminals procedure, page 122. The switch is located in the right side of the control terminals. It has only influence on DIx.

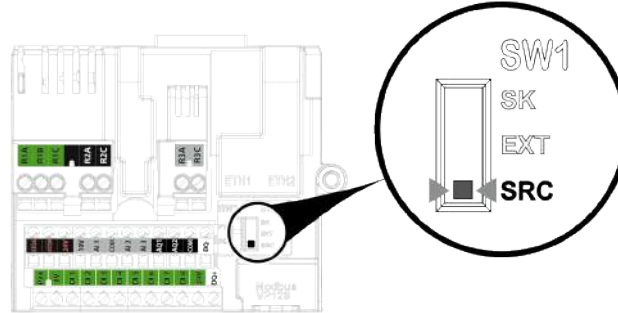

## Settings

Switch Position	Description	Power Supply
	<p>Source</p> <p>Set the switch to SRC Source (factory setting) if using PLC outputs with PNP transistors.</p> <p>Positive Logic PLC. Outputs switches to +24V when active. Common to Europe PLCs.</p>	<p>Can be used to supply 24 Vdc to switches.</p>
	<p>External (sink)</p> <p>Switch Set to EXT (Sink external) position and use of an External Power Supply</p>	<p>24 Vdc to supply all DIx internal logic</p>
	<p>Sink</p> <p>Set the switch to SK (Sink internal) if using PLC outputs with NPN transistors. Negative Logic PLC, Outputs switches to 0 V when active. Common to Asian PLCs.</p>	<p>Can be used to supply 0V to switches</p>

# PTO - DQ Switch (SW2) Configuration

## What's in This Chapter

PTO, Pulse Train Output Configuration on Frame Sizes 4 and 5.....	162
Digital Output Configuration on Frame Sizes 4 and 5.....	164

# PTO, Pulse Train Output Configuration on Frame Sizes 4 and 5

## Purpose

**⚠ WARNING**

**UNANTICIPATED EQUIPMENT OPERATION**

- If the device is set to **SK** or **EXT**, do not connect the **0 V** terminal to ground or to protective ground.
- Verify that accidental grounding of digital inputs configured for sink logic, caused, for example, by damage to the signal cables, cannot occur.
- Follow all applicable standards and directives such as NFPA 79 and EN 60204 for proper control circuit grounding practices.

**Failure to follow these instructions can result in death, serious injury, or equipment damage.**

The SW2 (PTO/DQ) switch is used to configure the DQ+ or DQ- digital outputs.

- Set the switch to **PTO (Pulse Train Output)** to configure DQ+ and DQ- outputs as pulse train outputs. This may be used to chain pulse train inputs of another drive, using its DI7 or DI8 pulse inputs.
- Set the switch to **DQ (Digital Output)** to configure DQ+ and DQ- outputs as an assignable logic output.

## Access

To access the switch, follow the Access to control Terminals procedure, page 122. The switch is located below the control terminals, page 127.

## Switches SW1 (A1&A2) Set to SK (Sink mode) Position

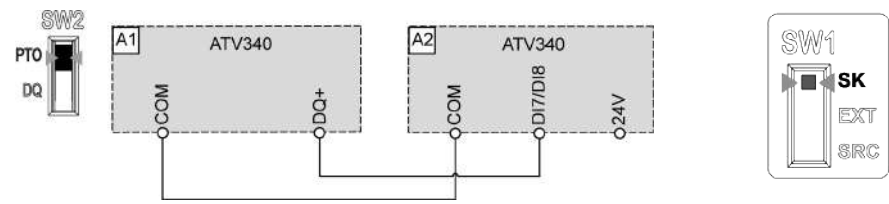

## Switches SW1 (A1&A2) Set to EXT (Sink ext mode) Position

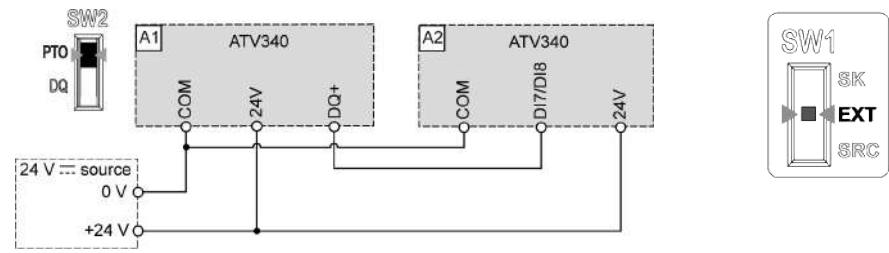

## Switches SW1 (A1&A2) Set to SRC (Source mode) Position

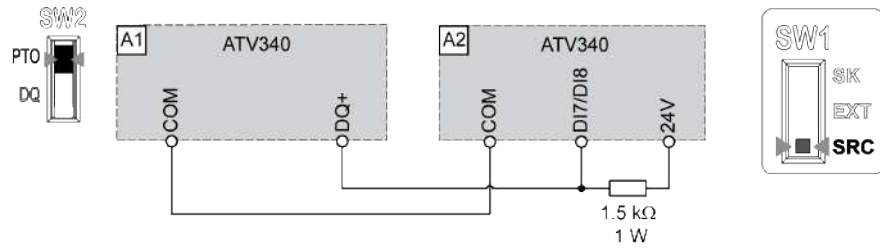

## Switches SW1 (A1&A2) Set to SRC (Source ext mode) Position

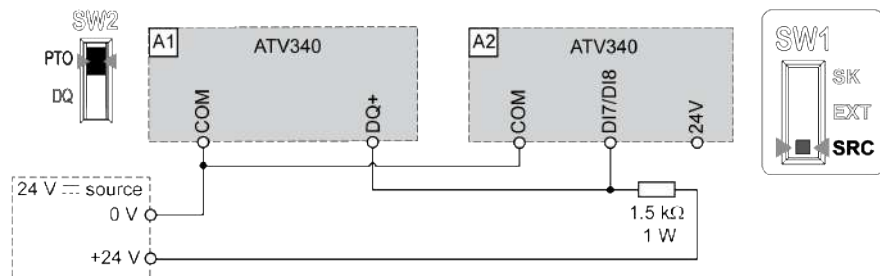

# Digital Output Configuration on Frame Sizes 4 and 5

## Purpose

<b>⚠ WARNING</b>
<p><b>UNANTICIPATED EQUIPMENT OPERATION</b></p> <ul style="list-style-type: none"> <li>• If the device is set to <b>SK</b> or <b>EXT</b>, do not connect the <b>0 V</b> terminal to ground or to protective ground.</li> <li>• Verify that accidental grounding of digital inputs configured for sink logic, caused, for example, by damage to the signal cables, cannot occur.</li> <li>• Follow all applicable standards and directives such as NFPA 79 and EN 60204 for proper control circuit grounding practices.</li> </ul> <p><b>Failure to follow these instructions can result in death, serious injury, or equipment damage.</b></p>

The SW2 (PTO/DQ) switch is used to configure the DQ+ or DQ- digital outputs.

- Set the switch to **PTO (Pulse Train Output)** to configure DQ+ and DQ- outputs as pulse train outputs. This may be used to chain pulse train inputs of another drive, using its DI7 or DI8 pulse inputs.
- Set the switch to **DQ (Digital Output)** to configure DQ+ and DQ- outputs as an assignable logic output.

## Access

To access the switch, follow the Access to control Terminals procedure, page 122.

The switch is located below the control terminals, page 127.

## Switch SW1 Set to SK (Sink mode) Position

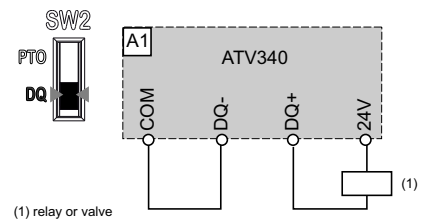
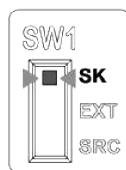

## Switch SW1 Set to EXT (Sink ext mode) Position

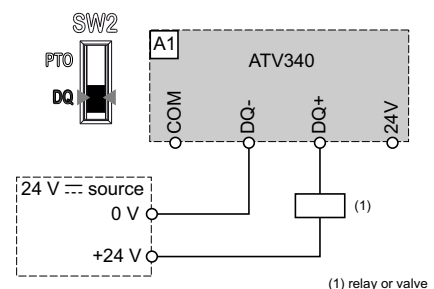

## Switch SW1 Set to SRC (Source mode) Position

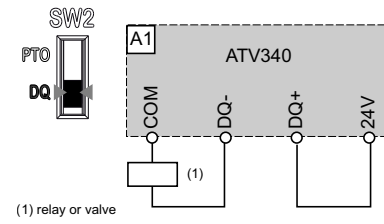
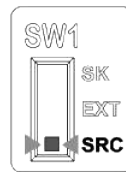

## Switch SW1 Set to SRC (Source ext mode) Position

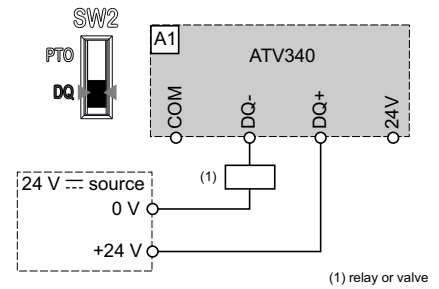
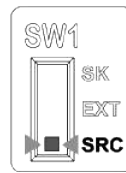

# Safe Torque Off STO Function

## What's in This Chapter

STO Safe Torque Off Wiring Diagram for Frame Sizes 1...3 .....	167
STO Safe Torque Off Wiring Diagram for Frame Sizes 4 and 5.....	167

# STO Safe Torque Off Wiring Diagram for Frame Sizes 1...3

## Wiring Diagram

All details related to the STO safety function activation are given in the Embedded Safety Function Manual NVE64143.

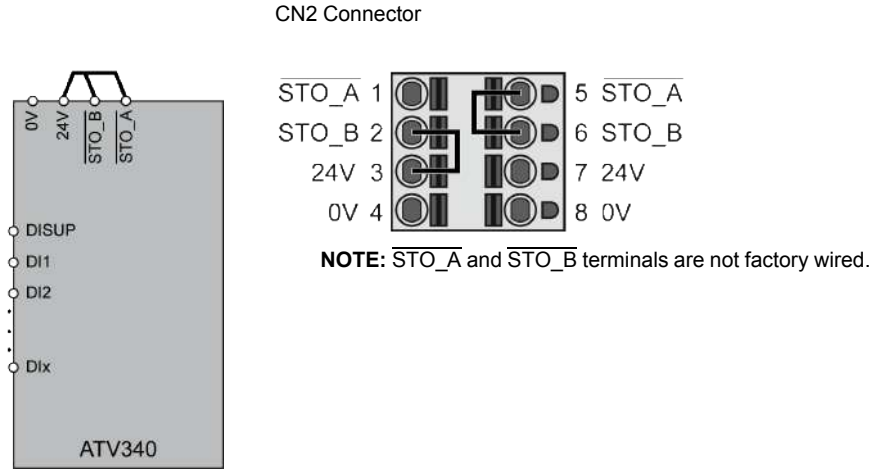

When not used for functional safety the STO inputs should be connected to 24V.

**NOTE:**

- On frame sizes 1, 2 and 3, the 24 V (pin 3) can be disabled using **[24V Supply Output] 5 24V** menu. If the 24 V Supply output is disabled the STO signals must be externally supplied. Refer to the programming manual.
- To avoid triggering the STO function when switching-on the product, the external power supply must be previously switched on.

# STO Safe Torque Off Wiring Diagram for Frame Sizes 4 and 5

## Wiring Diagram

All details related to the STO safety function activation are given in the Embedded Safety Function Manual NVE64143.



When not used for functional safety the STO inputs should be connected to 24V.

**NOTE:**

- On frame sizes 4 and 5, STO inputs are also connected by default on a 24 Vdc terminal. If the external power supply is switched off, the function STO will be triggered.
- To avoid triggering the STO function when switching-on the product, the external power supply must be previously switched on.

# Digital Inputs Wiring

## What's in This Chapter

Digital Inputs Wiring on Frame Sizes 1...3 .....	169
Digital Inputs Wiring on Frame Sizes 4 and 5, Depending on Sink / Source Switch Configuration.....	171

## Digital Inputs Wiring on Frame Sizes 1...3

**⚠ WARNING**

**UNANTICIPATED EQUIPMENT OPERATION**

- If the drive is set to **Sink Int** or **Sink Ext**, do not connect the **0 V** terminal to ground or to protective ground.
- Verify that accidental grounding of digital inputs configured for sink logic, caused, for example, by damage to the signal cables, cannot occur.
- Follow all applicable standards and directives such as NFPA 79 and EN 60204 for proper control circuit grounding practices.

**Failure to follow these instructions can result in death, serious injury, or equipment damage.**

### Digital Inputs: Internal Supply Using DISUP Signal

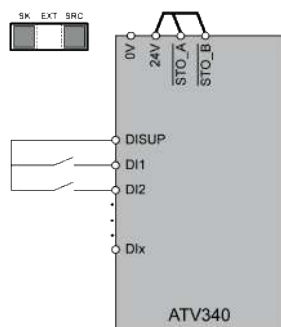

Switch can be set either to SK or SRC position. SRC setting recommended. In SRC position DISUP outputs 24 V. In SK position DISUP is connected to 0 V.

### Digital Inputs: Positive Logic, Source, European Style, External Supply

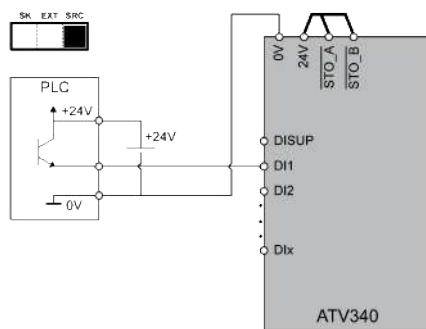

Set the switch to SRC position.

## Digital Inputs: Negative Logic, Sink, Asian Style, External Supply

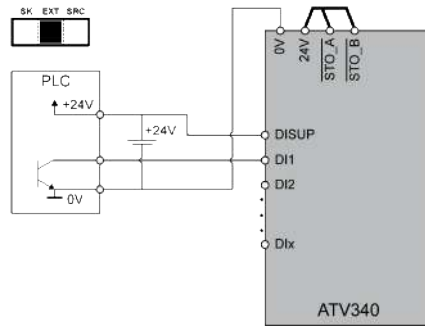

Set the switch to EXT position.

## Digital Inputs: Negative Logic, Sink, Asian Style, Internal supply

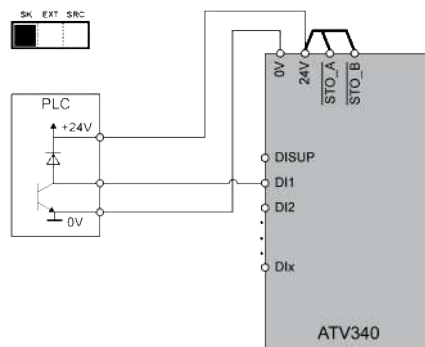

Set the switch to SK position.

## Digital Inputs: Two ATV340 Share The Same Switch

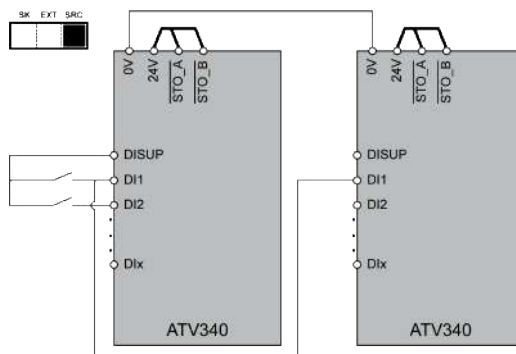

SRC setting recommended on both ATV340. With SK setting, an active switch will be detected when the second drive is switched-off.

## Digital Inputs: Negative Logic, Sink, Asian Style, Internal Supply - Two ATV340 Share The Same Switch

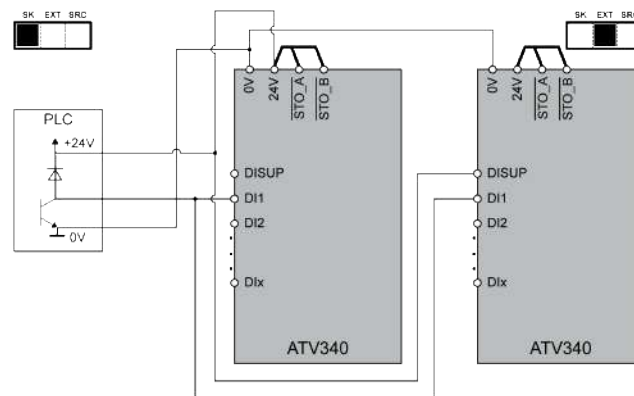

Set the switch to SK position on first drive. Set the switch to EXT position on the second drive.

Connect DISUP to 24V. Connect 0V.

## Digital Inputs Wiring on Frame Sizes 4 and 5, Depending on Sink / Source Switch Configuration

### About the Switch

#### ⚠ WARNING

##### UNANTICIPATED EQUIPMENT OPERATION

- If the drive is set to **Sink Int** or **Sink Ext**, do not connect the **0 V** terminal to ground or to protective ground.
- Verify that accidental grounding of digital inputs configured for sink logic, caused, for example, by damage to the signal cables, cannot occur.
- Follow all applicable standards and directives such as NFPA 79 and EN 60204 for proper control circuit grounding practices.

**Failure to follow these instructions can result in death, serious injury, or equipment damage.**

The switch is used to adapt the operation of the logic inputs to the technology of the programmable controller outputs. To access the switch, follow the Access to Terminals procedure , page 122. The switch is located on the right hand side of the control terminals , page 127.

- Set the switch to Source (factory setting) if using PLC outputs with PNP transistors.
- Set the switch to Ext if using PLC outputs with NPN transistors.

## Wiring With Use of the Output Power Supply for the Digital Inputs

Switch set to **SRC** (Source) position

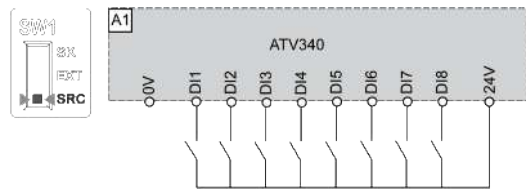

Switch set to **SK** (Sink) position

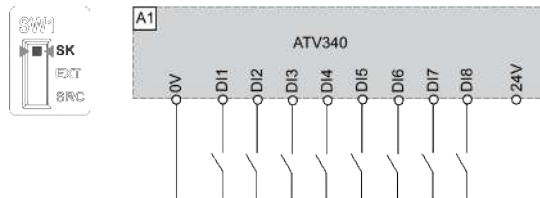

## Wiring Use of an External Power Supply for the Digital Inputs

⚡ ⚠ **DANGER**

**ELECTRIC SHOCK CAUSED BY INCORRECT POWER SUPPLY UNIT**

The +24VDC supply voltage is connected with many exposed signal connections in the device.

- Use a power supply unit that meets the PELV (Protective Extra Low Voltage) requirements.

**Failure to follow these instructions will result in death or serious injury.**

Switch set to **EXT** (Sink External) position **without functional isolation** on digital inputs

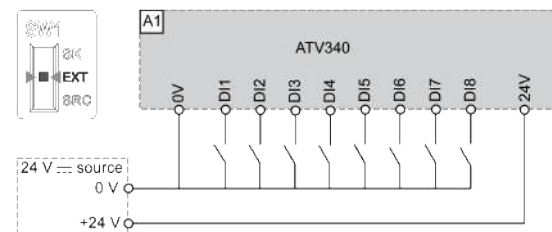

Switch set to **EXT** (Sink External) position **with functional isolation** on digital inputs. This configuration requires the use of 2 external supply units.

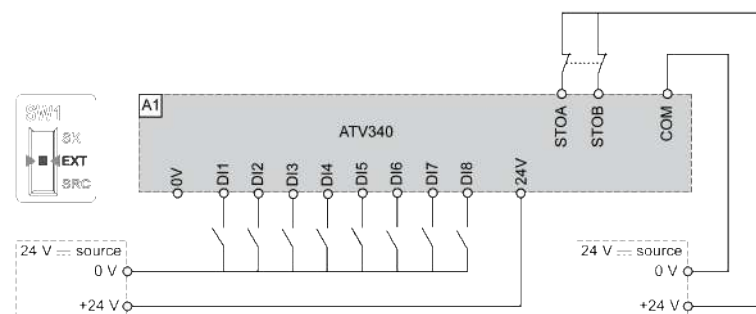

**NOTE:**

- STO inputs are also connected by default on a 24 Vdc terminal. If the external power supply is switched off, the function STO will be triggered.
- To avoid triggering the STO function when switching-on the product, the external power supply must be previously switched on.

Switch set to **SRC** (Source) position

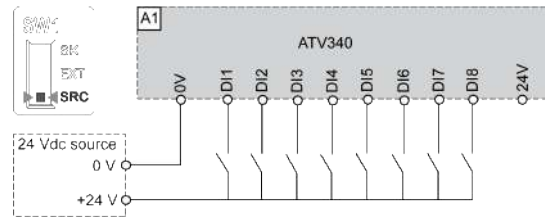

# Digital Outputs Wiring

## What's in This Chapter

Digital Outputs Wiring on Frame sizes 1...3 .....	175
Digital Outputs Wiring on Frame sizes 4 and 5.....	176

# Digital Outputs Wiring on Frame sizes 1...3

## Digital Outputs: Internal Supply

<b>NOTICE</b>
<p><b>INCORRECT VOLTAGE</b></p> <p>Supply the digital inputs with 24 Vdc only.</p> <p><b>Failure to follow these instructions can result in equipment damage.</b></p>

Positive Logic, Source, European Style,  
DQ switches to +24V

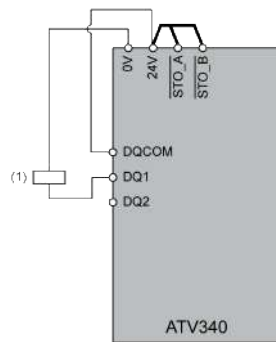

(1) relay or valve

Negative Logic, Sink, Asian Style,  
DQ switches to 0V

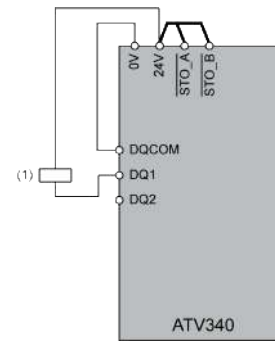

## Digital Outputs: External Supply

Positive Logic, Source, European Style,  
DQ switches to +24V

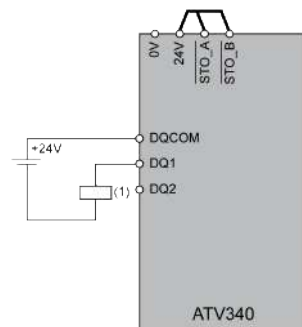

(1) relay or valve

Negative Logic, Sink, Asian Style,  
DQ switches to 0V

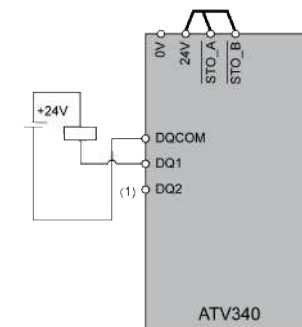

## DQ1 and DQ2 settings

The following table shows the possible settings. Refer to the CN6 connector terminal description, page 138, the control block wiring diagram, page 96, and the programming manual.

If...	Then...
DQ1 and DQ2 are not configured (factory setting)	DQ1 and DQ2 are digital outputs
DQ1 and DQ2 are configured as digital inputs	DQ1 and DQ2 become digital inputs DI6 (DQ1) and DI7 (DQ2)

**NOTE:**

- Hardware wiring and software settings must be consistent,
- It is not possible to set DQ1 and DQ2 to get digital input and digital output at the same time.

## Digital Outputs Wiring on Frame sizes 4 and 5

### Description and Wiring Diagrams

The SW2 (PTO/DQ) switch is used to configure the DQ or DQ- digital outputs.

Refer to the PTO - DQ Switch (SW2) Configuration section , page 164.

# Relay Contacts Wiring

## What's in This Chapter

Output Relay with Inductive AC Loads .....	178
Output Relay with Inductive DC loads .....	179

## Output Relay with Inductive AC Loads

### General

The AC voltage source must be of overvoltage category II (OVC II) according to IEC 61800-5-1.

If it is not the case, an isolation transformer must be used.

### Contactors with AC Coil

If controlled by a relay, a resistor-capacitor (RC) circuit must be connected in parallel to the coil of the contactor as shown on the diagram below:

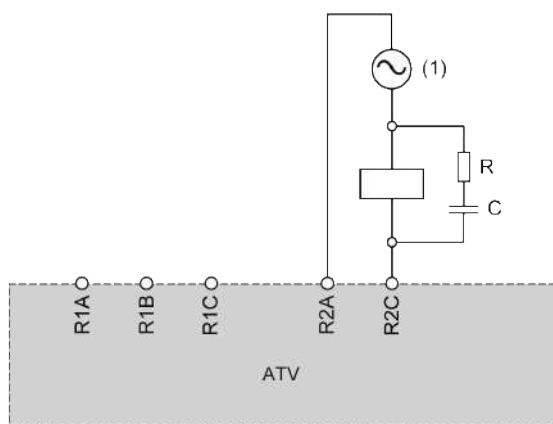

(1) AC 250 Vac maximum.

Schneider Electric AC contactors have a dedicated area on the housing to plug easily the RC device. Refer to the Motor control and protection components catalog MKTED210011EN available on [se.com](http://se.com) to find the RC device to be associated with the contactor used.

**Example:** With a 48 Vac source, contactors LC1D09E7 or LC1DT20E7 have to be used with LAD4RCE voltage suppression device.

### Other Inductive AC Loads

For other inductive AC loads:

- Use an auxiliary contactor connected on the product to control the load.

**Example:** with a 48 Vac source, auxiliary contactors CAD32E7 or CAD50E7 with LAD4RCE voltage suppression device.

- When using a third party inductive AC load, request the supplier to provide information on the voltage suppression device, in order to avoid overvoltage above 375 V during relay opening.

# Output Relay with Inductive DC loads

## Contactors with DC Coil

If controlled by a relay, a bidirectional transient voltage suppression (TVS) diode, also called transil, must be connected in parallel to the coil of the contactor as shown on the diagram below:

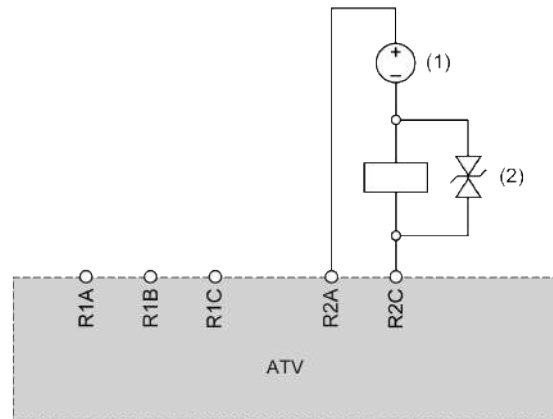

**(1)** DC 30 Vdc maximum.

**(2)** TVS diode

Schneider Electric contactors with DC coil include the TVS diode. No additional device is required.

Refer to the Motor control and protection components catalog MKTED210011EN available on [se.com](http://se.com) for more information.

## Other Inductive DC Loads

Other inductive DC loads without embedded TVS diode must use one of the following voltage suppression device:

- A bidirectional TVS device as shown on the diagram above, defined by:
  - TVS break-down voltage greater than 35 Vdc,
  - TVS clamping voltage V(TVS) less than 50 Vdc
  - TVS peak power dissipation greater than load rated current,  $I(\text{load}) \times V(\text{TVS})$ .

**Example:** with  $I(\text{load}) = 0.9 \text{ A}$  and  $V(\text{TVS}) = 50 \text{ Vdc}$ , TVS peak power must be greater than 45 W

- TVS average power dissipation greater than the value calculated by the following  $0.5 \times I(\text{load}) \times V(\text{TVS}) \times \text{load time constant} \times \text{number of operation per second}$ .

**Example:** with  $I(\text{load}) = 0.9 \text{ A}$  and  $V(\text{TVS}) = 50 \text{ Vdc}$ , load time constant = 40 ms (load inductance divided by load resistance) and 1 operation every 3 s, the TVS average power dissipation must be greater than  $0.5 \times 0.9 \times 50 \times 0.04 \times 0.33 = 0.3 \text{ W}$ .

- A fly-back diode as shown in the diagram below:

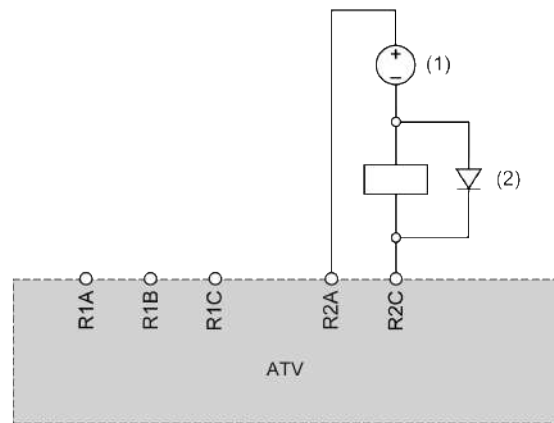

(1) DC 30 Vdc maxi.

(2) Flyback diode

The diode is a polarized device. The fly-back diode must be defined by:

- a reverse voltage greater than 100 Vdc,
- a rated current greater than two times the load rated current,
- a thermal resistance: junction to ambient temperature (in K/W) less than  $90 / (1.1 \times I(\text{load}))$  to operate at maximum 60°C (140°F) ambient temperature.

**Example:** with  $I(\text{load}) = 1.5 \text{ A}$ , select a 100 V, 3 A rated current diode with a thermal resistance from junction to ambient less than  $90 / (1.1 \times 1.5) = 54.5 \text{ K/W}$ .

Using a flyback diode, the relay opening time will be longer than with a TVS diode.

**NOTE:** Use diodes with leads for easy wiring and keep at least 1 cm (0.39 in.) of leads on each side of the case of the diode for a correct cooling.

## Before Switching On

The safety function STO (Safe Torque Off) does not remove power from the DC bus. The safety function STO only removes power to the motor. The DC bus voltage and the mains voltage to the drive are still present.

### **DANGER**

#### **HAZARD OF ELECTRIC SHOCK**

- Do not use the safety function STO for any other purposes than its intended function.
- Use an appropriate switch, that is not part of the circuit of the safety function STO, to disconnect the product from the mains power.

**Failure to follow these instructions will result in death or serious injury.**

Unsuitable settings or unsuitable data or unsuitable wiring may trigger unintended movements, trigger signals, damage parts and disable monitoring functions.

### **WARNING**

#### **UNANTICIPATED EQUIPMENT OPERATION**

- Only start the system if there are no persons or obstructions in the zone of operation.
- Verify that a functioning emergency stop push-button is within reach of all persons involved in the operation.
- Do not operate the product with unknown settings or data.
- Verify that the wiring is appropriate for the settings.
- Never modify a parameter unless you fully understand the parameter and all effects of the modification.
- When commissioning, carefully run tests for all operating states, operating conditions and potential error situations.
- Anticipate movements in unintended directions or oscillation of the motor.

**Failure to follow these instructions can result in death, serious injury, or equipment damage.**

If the power stage is disabled unintentionally, for example as a result of power outage, errors or functions, there is a possibility that the motor is no longer decelerated in a controlled way.

### **WARNING**

#### **UNANTICIPATED EQUIPMENT OPERATION**

Verify that movements without braking effect does not result in unsafe conditions.

**Failure to follow these instructions can result in death, serious injury, or equipment damage.**

## Mechanical Installation

Verify the mechanical installation of the entire drive system:

Step	Action	✓
1	Does the installation meet the specified distance requirements?	
2	Did you tighten all fastening screws with the specified tightening torque?	

## Electrical installation

Verify the electrical connections and the cabling:

Step	Action	✓
1	Did you connect all protective ground conductors?	
2	The correct tightening of the screws may be altered during assembly and wiring phases of the drive.  Verify and adjust the tightening of all terminal screws to the specified nominal torque.	
3	Do all fuses and circuit breaker have the correct rating; are the fuses of the specified type? (refer to the information provided in the ATV340 Getting Started Annex (SCCR), catalog number NVE37641) for UL/CSA compliance and also in the catalog for IEC compliance.	
4	Did you connect or insulate all wires at the cable ends?	
5	Did you properly connect and install all cables and connectors?	
6	Did you properly connect the signal wires?	
7	Did you properly separate and insulate control cabling / power cabling?	
8	Are the required shield connections EMC-compliant?	
9	Did you take all measures for EMC compliance?	

## Covers And Seals

Verify that all devices, doors and covers of cabinet are properly installed to meet the required degree of protection.

---

# Maintenance

## What's in This Part

Scheduled Servicing.....	184
Long-term Storage .....	186
Decommissioning.....	187
Additional Support.....	188

# Scheduled Servicing

## Serviceable products

The drives of frame sizes 1...3 are not serviceable products.

For drives of frame sizes 4 and 5 servicing, please refer to your Customer Care Center [www.se.com/CCC](http://www.se.com/CCC).

## Servicing

### **DANGER**

#### **HAZARD OF ELECTRIC SHOCK, EXPLOSION OR ARC FLASH**

Read and understand the instructions in **Product Related Information** chapter before performing any procedure in this chapter.

**Failure to follow these instructions will result in death or serious injury.**

The temperature of the products described in this manual may exceed 80 °C (176 °F) during operation.

### **WARNING**

#### **HOT SURFACES**

- Ensure that any contact with hot surfaces is avoided.
- Do not allow flammable or heat-sensitive parts in the immediate vicinity of hot surfaces.
- Verify that the product has sufficiently cooled down before handling it.
- Verify that the heat dissipation is sufficient by performing a test run under maximum load conditions.

**Failure to follow these instructions can result in death, serious injury, or equipment damage.**

### **WARNING**

#### **INSUFFICIENT MAINTENANCE**

Verify that the maintenance activities described below are performed at the specified intervals.

**Failure to follow these instructions can result in death, serious injury, or equipment damage.**

Adherence to the environmental conditions must be ensured during operation of the device. In addition, during maintenance, verify and, if appropriate, correct all factors that may have an impact on the environmental conditions.

**Maintenance Activities**

	Part concerned	Activity	Interval (1)
Overall condition	All parts such as housing, HMI, control block, connections, etc.	Perform a visual inspection	At least every year
Corrosion	Terminals, connectors, screws, EMC plate	Inspect and clean if required	
Dust	Terminals, fans, cabinet air inlets and air outlets, air filters of cabinet	Inspect and clean if required	
Cooling	Fan	Verify the fan operation	At least every year
Fastening	All screws for electrical and mechanical connections	Verify tightening torques	At least every year
<p>(1)Maximum maintenance intervals from the date of commissioning. Reduce the intervals between maintenance to adapt maintenance to the environmental conditions, the operating conditions of the drive, and to any other factor that may influence the operation and/ or maintenance requirements of the drive.</p>			

**NOTE:** The fan operation depends on the drive thermal state. The drive may be running and the fan not.

Fans may continue to run for a certain period of time even after power to the product has been disconnected.

⚠ CAUTION
RUNNING FANS
Verify that fans have come to a complete standstill before handling them.
<b>Failure to follow these instructions can result in injury or equipment damage.</b>

## Diagnostic And Troubleshooting

Refer to the ATV340 Programming manual.

## Spares and repairs

Serviceable products:

Please refer to your Customer Care Center on [www.se.com/CCC](http://www.se.com/CCC).

# Long-term Storage

## Capacitor Reforming

If the drive was not connected to mains for an extended period of time, the capacitors must be restored to their full performance before the motor is started.

### **NOTICE**

#### **REDUCED CAPACITOR PERFORMANCE**

- Apply mains voltage to the drive for one hour before starting the motor if the drive has not been connected to mains for the specified periods of time.(1)
- Verify that no Run command can be applied before the period of one hour has elapsed.
- Verify the date of manufacture if the drive is commissioned for the first time and run the specified procedure if the date of manufacture is more than 12 months in the past.

**Failure to follow these instructions can result in equipment damage.**

(1) Period of time:

- 12 months at a maximum storage temperature of +50°C (+122°F)
- 24 months at a maximum storage temperature of +45°C (+113°F)
- 36 months at a maximum storage temperature of +40°C (+104°F)

If the specified procedure cannot be performed without a Run command because of internal mains contactor control, perform this procedure with the power stage enabled, but the motor being at a standstill so that there is no appreciable mains current in the capacitors.

# Decommissioning

## Uninstall the Product

Observe the following procedure when uninstalling the product.

- Switch off all supply voltage. Verify that no voltages are present - refer to the *Verifying the Absence of Voltage*, page 17.
- Remove all connection cables.
- Uninstall the product.

## End of Life

The components of the product consist of different materials which can be recycled and which must be disposed of separately.

- Dispose of the packaging in compliance with all applicable regulations.
- Dispose of the product in compliance with all applicable regulations.

Refer to the *Environmental Data Program* for information and documents on environmental protection such as EoLI (End of Life instruction).

# Additional Support

## Customer Care Center

For additional support, you can contact our Customer Care Center on:

[www.se.com/CCC](http://www.se.com/CCC).

# Glossary

## A

### Abbreviations:

Req. = Required

Opt. = Optional

### AC:

Alternating Current

**Adjustment parameter:** A parameter always accessible as **[Access Level]**.

## C

**Configuration Parameter:** A parameter affected by the operating states of the machine as **[Motor Nom Current]**.

## D

### DC:

Direct Current

## E

### ELV:

Extra-Low Voltage. For more information: IEC 60449

### Error :

Discrepancy between a detected (computed, measured, or signaled) value or condition and the specified or theoretically correct value or condition.

## F

### Factory setting:

Machine status in factory settings when the product was shipped.

### Fault Reset:

A function used to restore the drive to an operational state after a detected error is cleared by removing the cause of the error so that the error is no longer active.

### Fault:

Fault is an operating state. If the monitoring functions detect an error, a transition to this operating state is triggered, depending on the error class. A "Fault reset" is required to exit this operating state after the cause of the detected error has been removed. Further information can be found in the pertinent standards such as IEC 61800-7, ODVA Common Industrial Protocol (CIP).

## G

### GP:

General-Purpose

## L

### **L/R:**

Time constant equal to the quotient of inductance value (L) over the resistance value (R).

## N

### **NC contact:**

Normally Closed contact

### **NO contact:**

Normally Open contact

## O

### **OEM:**

Original Equipment Manufacturer

### **OVCII:**

Overvoltage Category II, according IEC 61800-5-1

## P

### **PA/+:**

DC bus terminal

### **PC/-:**

DC bus terminal

### **PELV:**

Protective Extra Low Voltage, low voltage with isolation. For more information: IEC 60364-4-41.

### **PLC:**

Programmable logic controller.

### **Power stage:**

The power stage controls the motor. The power stage generates current for controlling the motor.

### **PTC:**

Positive Temperature Coefficient. PTC thermistor probes integrated in the motor or application to measure its temperature

### **PWM:**

Pulse Width Modulation.

## R

### **REACH:**

Registration, Evaluation, Authorisation and restriction of Chemicals regulation

### **RoHS:**

Restriction of Hazardous Substances

**S****SCPD:**

Short-Circuit Protective Device

**STO:**

Safe Torque Off: No power that could cause torque or force is supplied to the motor

**T****TVS Diode:**

Transient Voltage Suppression Diode

**V****VHP:**

Very High Horse Power (> 800 kW)

**VSD:**

Variable Speed Drive

**W****Warning:**

If the term is used outside the context of safety instructions, a warning alerts to a potential error that was detected by a monitoring function. A warning does not cause a transition of the operating state.

Schneider Electric  
35 rue Joseph Monier  
92500 Rueil Malmaison  
France

+ 33 (0) 1 41 29 70 00

[www.se.com](http://www.se.com)

As standards, specifications, and design change from time to time, please ask for confirmation of the information given in this publication.

© 2018 – 2025 Schneider Electric. All rights reserved.

NVE61069.06 — 10/2025